

FLOAT AND THERMOSTATIC STEAM TRAPS FLT29 (SG iron 2"; DN 50)

DESCRIPTION

The FLT29 is a range of float and thermostatic steam traps with integral air vent designed for modulating discharge of condensate, ensuring maximum system heat transfer.

Typical applications include unit heaters, heat exchangers, dryers, jacketed vessels and other applications where continuous discharge is essential and high flow capacities are involved.

MAIN FEATURES

- Modulating discharge of condensate at steam temperature.
- Unaffected by sudden or wide load and pressure variations.
- No backing-up with condensate.
- Excellent air discharge through its integrated air vent.
- Flow direction can be easily changed by repositioning the body in relation to the mechanism and cover.

- OPTIONS:**
- Equalizing (vent) and drain connections.
 - SLR – Steam lock release.
 - HVV – Hand vent valve.
 - BDV – Blowdown valve.
 - AFZ – Anti-freeze device.
 - FLL – Float lifting lever.
 - VB21M – Vacuum breaker.

USE: Saturated and superheated steam.

AVAILABLE MODELS: FLT29-4,5 , 10 and 14 – SG iron.

SIZES: 2"; DN 50.

CONNECTIONS: Female threaded ISO 7 Rp or NPT.
Flanged EN 1092-2 PN 16.
Flanged ASME B16.42 Class 150.

INSTALLATION: Horizontal or vertical installation.

MAX. ΔP:
FLT29-4,5 – 4,5 bar
FLT29-10 – 10 bar
FLT29-14 – 14 bar



CE MARKING – GROUP 2 (PED – European Directive)	
PN 16	Category
2" – DN 50	1 (CE marked)

BODY LIMITING CONDITIONS		
FLANGED PN 16 *	FLANGED CLASS 150 **	RELATED TEMP.
ALLOWABLE PRESSURE	ALLOWABLE PRESSURE	
16 bar	16 bar	100 °C
15,5 bar	14,8 bar	150 °C
14,7 bar	13,9 bar	200 °C
13,9 bar	12,1 bar	250 °C

PMO – Maximum operating pressure: 14 bar.
TMO – Maximum operating temperature: 250 °C.
* Acc. to EN 1092-2:2018; ** Acc. to ASME B16.42.
Body limiting conditions PN 16 or below, depending on the type of connection adopted. Rating PN 16 for threaded versions.

FLOW RATE CAPACITY (kg/h)										
MODEL	SIZE	DIFFERENTIAL PRESSURE (bar)								
		0,5	1	1,5	2	4,5	7	10	12	14
FLT29-4,5	2" – DN 50	7550	11000	14000	15500	22500	–	–	–	–
FLT29-10	2" – DN 50	3900	5000	6100	7100	10000	13750	16000	–	–
FLT29-14	2" – DN 50	1900	2700	3100	3600	5000	6900	8100	9000	9800

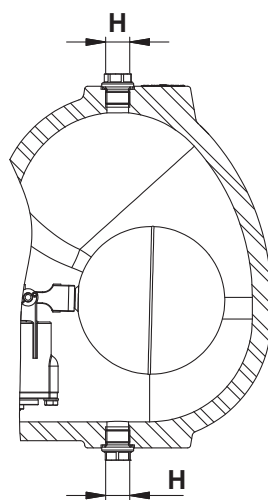
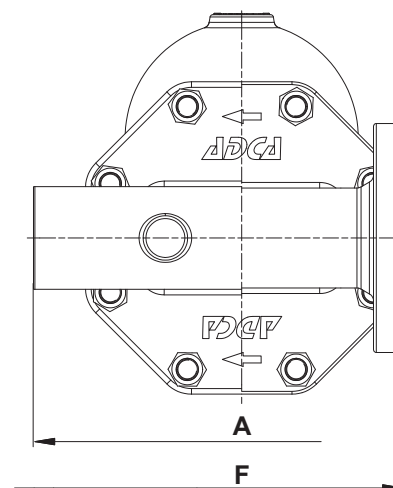
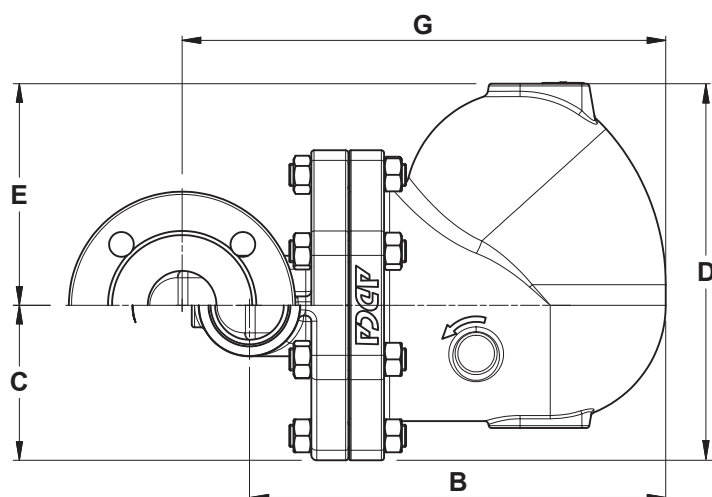

DIMENSIONS (mm)													
THREADED								PN 16			CLASS 150		
SIZE	A	B	C	D	E	H *	WGT. (kg)	F	G	WGT. (kg)	F	G	WGT. (kg)
2" – DN 50	300	303	80	215	136	3/8"	35,5	230	352	40,8	230	352	39,9

* As standard, in versions with EN flanges and female ISO 7 Rp threads, these connections are female threaded ISO 228. In versions with ASME flanges or female NPT threads, these connections are female threaded NPT.

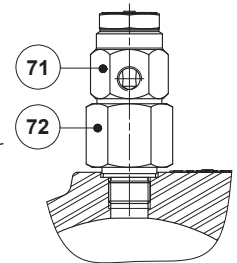
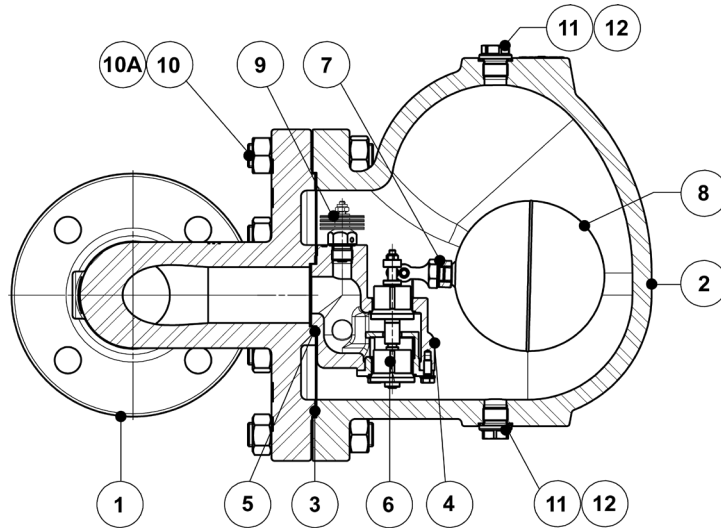

VB21M - Vacuum breaker

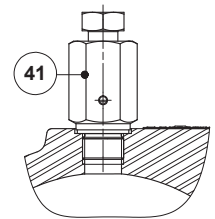

HVV - Hand vent valve

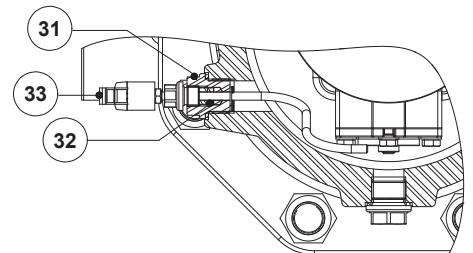

FLL - Float lifting lever

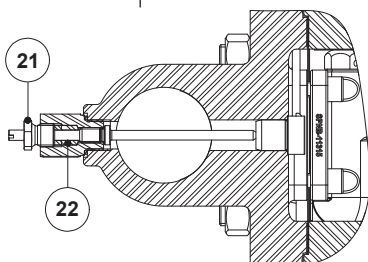

SLR - Steam lock release

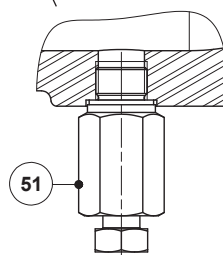

BDV - Blowdown valve
(Manual)

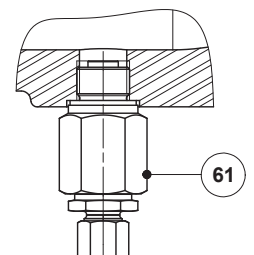

AFZ - Anti-freeze device
(Automatic)

MATERIALS		
POS. N°	DESIGNATION	MATERIAL
1	Body (Flanged)	GJS-400-15 / 0.7040
	Body (Threaded)	A216 WCB / 1.0619
2	Cover	GJS-400-15 / 0.7040
3	* Gasket	Stainless steel / Graphite
4	* Seat	A351 CF8 / 1.4308; A276-98B / 1.4057
5	* Gasket	Graphite
6	* Valve	AISI 316 / 1.4401; AISI 420 / 1.4021
7	* Lever	A351 CF8M / 1.4408
8	* Float	AISI 304 / 1.4301
9	* Automatic air vent	Stainless st. (bimetallic)
10	Studs	Zinc plated steel
10A	Nuts	Zinc plated steel
11	Plug	AISI 316L / 1.4404
12	** Gasket	Copper; AISI 304 / 1.4301
21	Steam Lock Release	AISI 420 / 1.4021 AISI 316L / 1.4404
22	Packing	Graphite
31	Lever mechanism	AISI 303 / 1.4305; AISI 304 / 1.4301; AISI 316L / 1.4404
32	Packing	Graphite
33	Lever	Plastic
41	Hand vent valve	AISI 303 / 1.4305; AISI 316L / 1.4404
51	Blowdown valve	AISI 303 / 1.4305; AISI 316L / 1.4404
61	Anti-freeze device	AISI 303 / 1.4305; AISI 316L / 1.4404
71	Vacuum breaker	AISI 303 / 1.4305
72	Adapter fitting	AISI 303 / 1.4305

* Available spare parts; ** Not applicable in NPT version.

FLOW DIRECTION

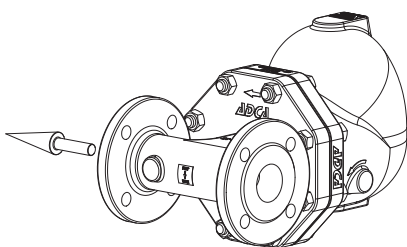

IR - Horizontal from right to left

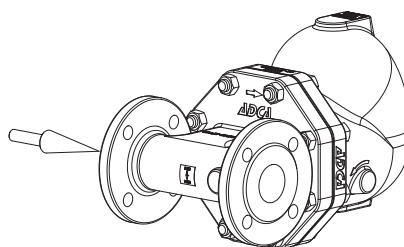

IL - Horizontal from left to right

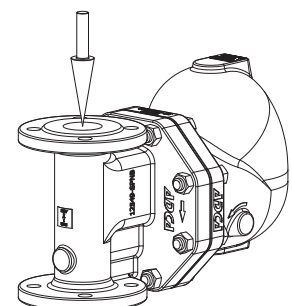

IT - Vertical from top to bottom

ORDERING CODES FLT29										
Model	A29	2	V	XX	X	X	IR	A	50	
FLT29	A29									
Differential pressure										
4,5 bar		2								
10 bar		3								
14 bar		4								
Automatic air vent										
Bimetallic air vent (standard)			V							
None			X							
Cover connections										
None				XX						
3/8" threaded connections on top and bottom, closed with plugs (mandatory if any options are considered)				10						
Options										
If any, these have specific separate ordering codes, please refer to the appropriate documentation.										
SLR - Steam lock release										
None					X					
With steam lock release assembled					S					
FLL - Float lifting lever										
None						X				
Lifting lever on the right side (when facing the steam trap body)							R			
Lifting lever on the left side (when facing the steam trap body)							L			
Flow direction										
Horizontal from right to left (standard)								IR		
Horizontal from left to right								IL		
Vertical from top to bottom								IT		
Pipe connections										
Female threaded ISO 7 Rp									A	
Female threaded NPT									C	
Flanged EN 1092-2 PN 16									L	
Flanged ASME B16.42 Class 150									U	
Size										
2" or DN 50									50	
Special valves / Extras										
Full description or additional codes have to be added in case of a non-standard combination										E