

FLOAT AND THERMOSTATIC STEAM TRAPS FLT39TW (Carbon steel 3" – 4"; DN 80 – 100)

DESCRIPTION

The FLT39TW is a range of high capacity float and thermostatic steam traps with integral air vent designed for modulating discharge of condensate, ensuring maximum system heat transfer.

Typical applications include unit heaters, heat exchangers, dryers, jacketed vessels and other applications where continuous discharge is essential and high flow capacities are involved.

MAIN FEATURES

Modulating discharge of condensate at steam temperature.

Unaffected by sudden or wide load and pressure variations.

No backing-up with condensate.

Excellent air discharge through its integrated air vent.

Flow direction can be easily changed by repositioning the body in relation to the mechanism and cover.

OPTIONS: Equalizing (vent) and drain connections.
 HVV – Hand vent valve.
 BDV – Blowdown valve.
 AFZ – Anti-freeze device.
 VB21M – Vacuum breaker.

USE: Saturated and superheated steam.

AVAILABLE MODELS: FLT39TW-4,5 , 10 , 21 and 32 – carbon steel.

SIZES: 3" to 4"; DN 80 to DN 100.

CONNECTIONS: Flanged EN 1092-1 PN 16 or PN 40.
 Flanged ASME B16.5 Class 150 or 300.

INSTALLATION: Horizontal or vertical installation.

MAX. ΔP: FLT39TW-4,5 – 4,5 bar
 FLT39TW-10 – 10 bar
 FLT39TW-21 – 21 bar
 FLT39TW-32 – 32 bar



CE MARKING – GROUP 2 (PED – European Directive)		
PN 16	PN 40	Category
3" to 4" DN 80 to 100	–	1 (CE marked)
–	3" to 4" DN 80 to 100	2 (CE marked)

BODY LIMITING CONDITIONS			
FLANGED PN 16 *	FLANGED PN 40 / CLASS 300 *	FLANGED CLASS 150 **	RELATED TEMP.
ALLOWABLE PRESSURE	ALLOWABLE PRESSURE	ALLOWABLE PRESSURE	
14,8 bar	37,1 bar	17,7 bar	100 °C
13,3 bar	33,3 bar	14 bar	200 °C
12,1 bar	30,4 bar	12,1 bar	250 °C
11 bar	27,6 bar	10,2 bar	300 °C

PMO – Maximum operating pressure: 32 bar;

TMO – Maximum operating temperature: 250 °C.

* Acc. to EN 1092-1:2018; ** Acc. to EN 1759-1:2004.

Body limiting conditions PN 40 or below, depending on the type of connection adopted.

FLOW RATE CAPACITY (kg/h)														
MODEL	SIZE	DIFFERENTIAL PRESSURE (bar)												
		0,5	1	1,5	2	4,5	7	10	12	14	16	21	25	32
FLT39TW-4,5	3" to 4" – DN 80 to 100	15100	22000	28000	31000	45000	–	–	–	–	–	–	–	–
FLT39TW-10	3" to 4" – DN 80 to 100	7800	10000	12200	14200	20000	27500	32000	–	–	–	–	–	–
FLT39TW-21	3" to 4" – DN 80 to 100	3800	5400	6200	7200	10000	13800	16200	18000	19600	20100	22300	–	–
FLT39TW-32	3" to 4" – DN 80 to 100	3800	5400	6200	7200	10000	13800	16200	18000	19600	20100	22300	24000	25100

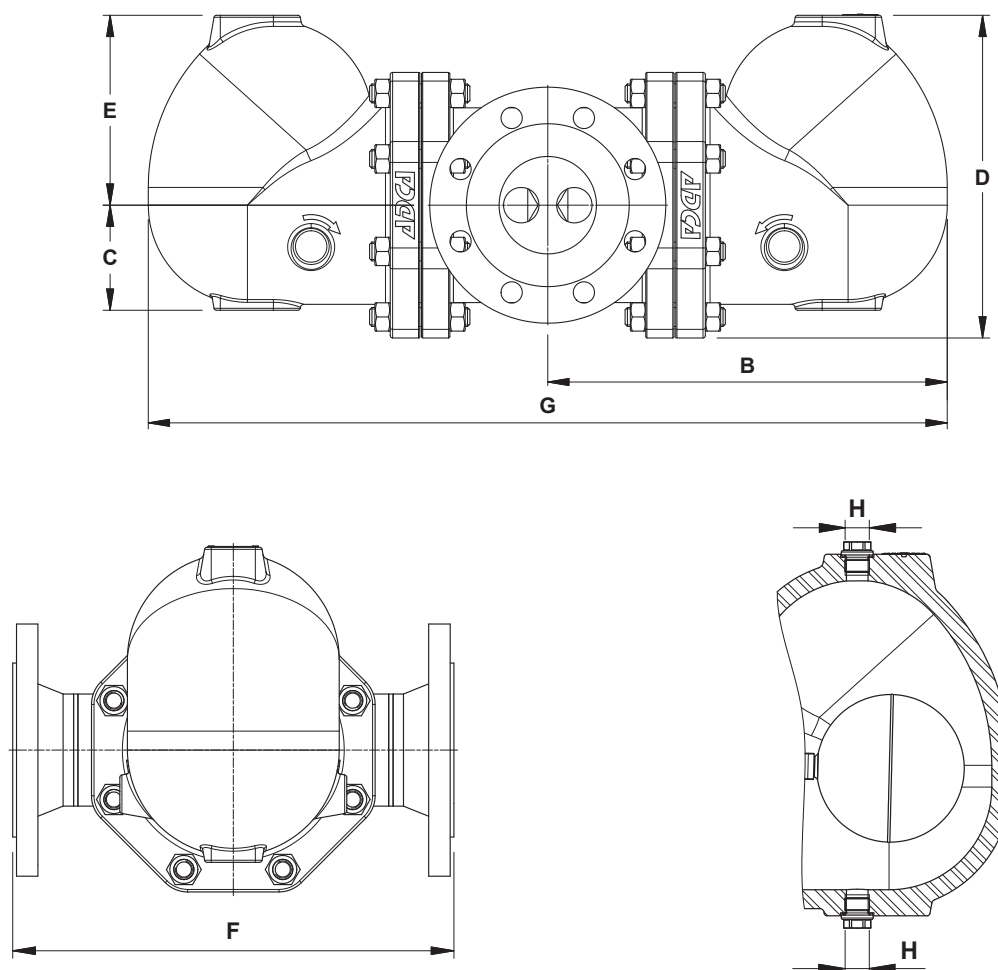

DIMENSIONS (mm)											
SIZE	PN 16							PN 40	CLASS 150	CLASS 300	
	B	C	D	E	F	G	H *	WEIGHT (kg)	WEIGHT (kg)	WEIGHT (kg)	WEIGHT (kg)
3" – DN 80	339	113	273	161	350	677	3/8"	89,3	90,9	90,4	94,2
4" – DN 100	339	113	273	161	350	677	3/8"	88,5	92	91,7	100,2

* As standard, in versions with EN flanges, these connections are female threaded ISO 228. In versions with ASME flanges, these connections are female threaded NPT.

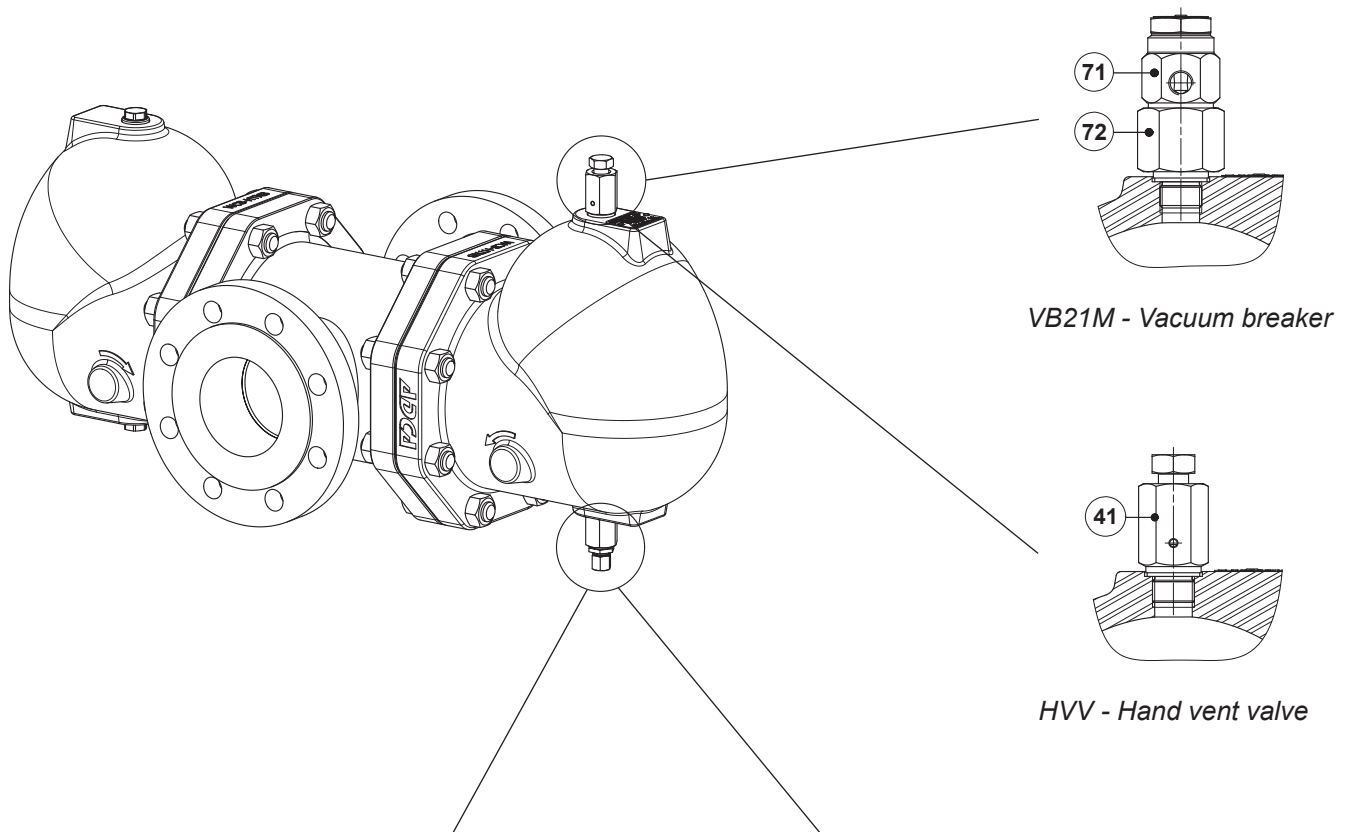
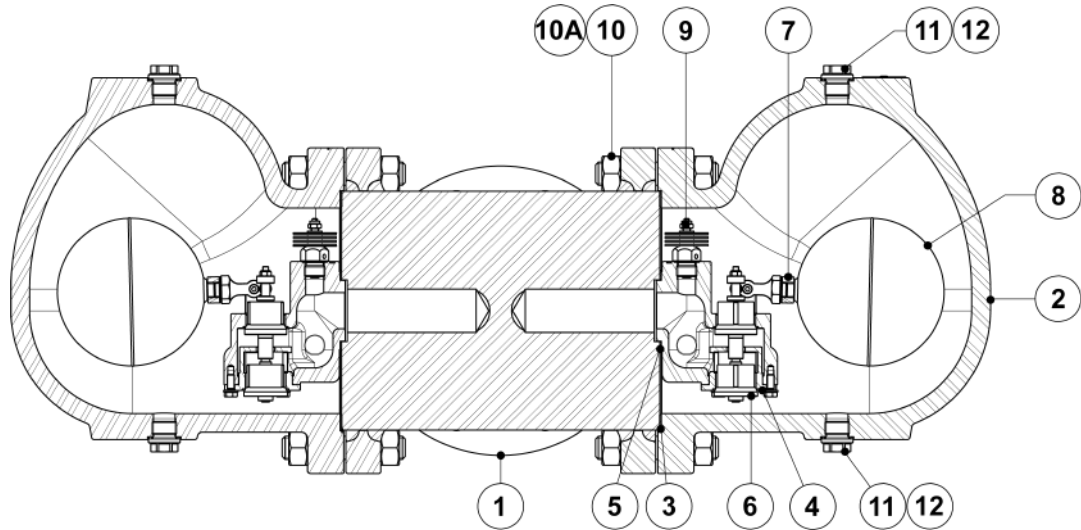

VB21M - Vacuum breaker

HVV - Hand vent valve

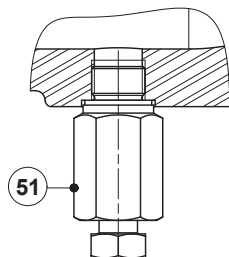

BDV - Blowdown valve
(Manual)

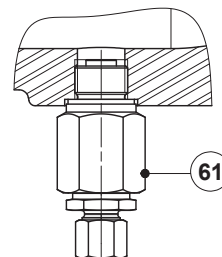

AFZ - Anti-freeze device
(Automatic)

MATERIALS		
POS. N°	DESIGNATION	MATERIAL
1	Body	P250GH / 1.0460; P235GH / 1.0345; S235JR / 1.0038
2	Cover	A216 WCB / 1.0619
3	* Gasket	Stainless steel / Graphite
4	* Seat	A351 CF8 / 1.4308; A276-98B / 1.4057
5	* Gasket	Graphite
6	* Valve	AISI 316 / 1.4401; AISI 420 / 1.4021
7	* Lever	A351 CF8M / 1.4408
8	* Float	AISI 304 / 1.4301
9	* Automatic air vent	Stainless steel (bimetallic)
10	Studs	Zinc plated steel
10A	Nuts	Zinc plated steel
11	Plug	AISI 316L / 1.4404
12	** Gasket	Copper; AISI 304 / 1.4301
41	Hand vent valve	AISI 303 / 1.4305; AISI 316L / 1.4404
51	Blowdown valve	AISI 303 / 1.4305; AISI 316L / 1.4404
61	Anti-freeze device	AISI 303 / 1.4305; AISI 316L / 1.4404
71	Vacuum breaker	AISI 303 / 1.4305
72	Adapter fitting	AISI 303 / 1.4305

* Available spare parts; ** Not applicable in NPT version.

FLOW DIRECTION

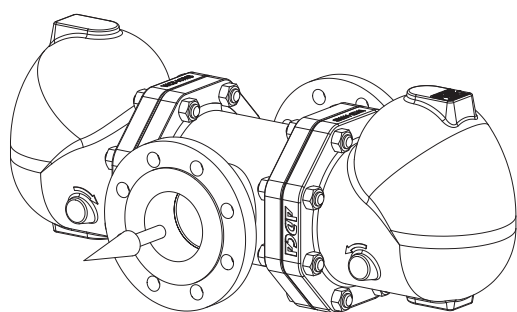

IH - Horizontal

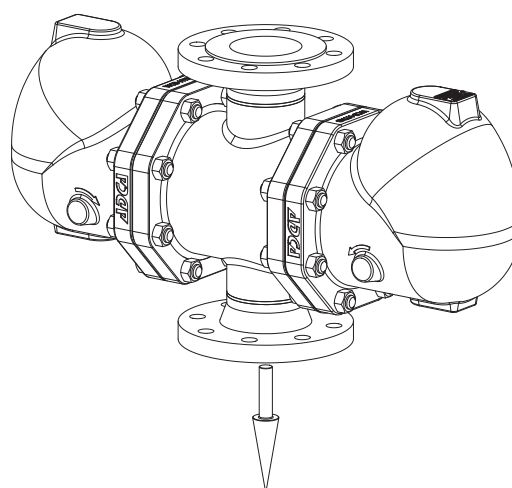

IT - Vertical from top to bottom

ORDERING CODES FLT39TW								
Model	A39T	2	V	XX	IH	L	80	E
FLT39TW – A216 WCB / 1.0619 carbon steel	A39T							
Differential pressure								
4,5 bar		2						
10 bar		3						
21 bar		4						
32 bar		5						
Automatic air vent								
Bimetallic air vent (standard)			V					
None			X					
Cover connections								
None				XX				
3/8" threaded connections on top and bottom, closed with plugs (mandatory if any options are considered)				10				
Options								
HVV, BDV, AFZ and VB21M have specific separated ordering codes, please refer to the appropriate documentation.								
Flow direction								
Horizontal					IH			
Vertical from top to bottom					IT			
Pipe connections								
Flanged EN 1092-1 PN 16						L		
Flanged EN 1092-1 PN 40						N		
Flanged ASME B16.5 Class 150						U		
Flanged ASME B16.5 Class 300						V		
Size								
3" or DN 80							80	
4" or DN 100							100	
Special valves / Extras								
Full description or additional codes have to be added in case of a non-standard combination								E