

## BLOWDOWN / DEPRESSURIZATION AND VENT VALVES BDV - BDVL - HVV - AFZ

### DESCRIPTION

The BDV, AFZ and HVV vent valves are designed to drain (blowdown) or vent (depressurize) pipework, steam traps, valves and others.

**USE:**

**BDV** – Blowdown valves – Manual discharge of strainer screen contents and generally to be used as a drain and/or depressurization valve.

**BDVL** – Same as above, but also allows the discharge to be connected to a safe location.

**HVV** – Hand vent valves – Venting of float traps and generally to be used as a vent or depressurization valve.

**AFZ** – Anti-freeze device – Automatic discharge of condensate from steam traps, valves, pipelines and others, to prevent the condensate from freezing.

### AVAILABLE MODELS:

BDV, BDVL, AFZ, HVV.

### SIZES:

3/8" and M22.

### CONNECTIONS:

NPT-M.  
ISO 228.  
Metric fine pitch.



BDV



BDVL



AFZ



HVV

### LIMITING CONDITIONS

Body design conditions	PN100
TMO – Maximum operating temperature	400 °C
PMO – Maximum operating pressure	42 bar
AFZ opening pressure	≈ 0,2 bar
AFZ closing pressure	≈ 0,3 bar

### DIMENSIONS WHEN APPLYING BDV TO STEAM TRAPS AND UNIVERSAL CONNECTORS (mm)

SIZE	BDV SIZE	STEAM TRAP MODEL															
		DT46		DT42/2		TH32		BM20		BM32		CDV		UCX41		CTS4U	
		E	F	E	F	E	F	E	F	E	F	E	F	E	F	E	F
1/2" – DN 15	M22	83	94	83	94	83	94	83	94	83	94	83	94	83	102	94	148
3/4" – DN 20	M22	83	94	83	94	83	94	83	94	83	94	83	94	83	102	94	148
1" – DN 25	M22	90	100	90	100	90	100	90	100	90	100	90	100	83	108	–	–

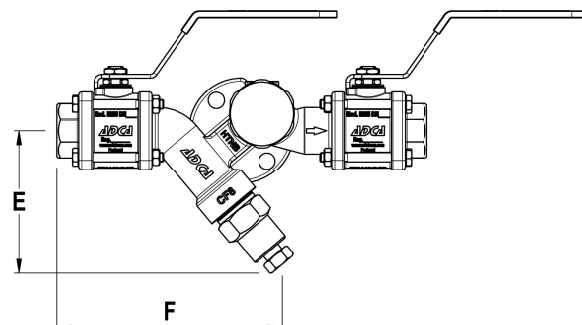
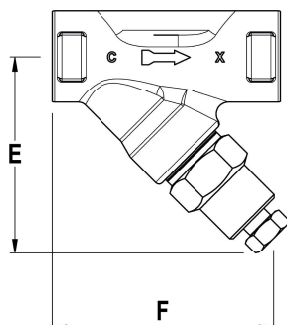

DIMENSIONS (mm) – BDV					
SIZE	A	B	SW1	SW2	WEIGHT (kg)
3/8"	61	50	24	17	0,16
M22	60	48	30	17	0,205

DIMENSIONS (mm) – BDVL						
SIZE	A	B	C	SW1	SW2	WEIGHT (kg)
3/8"	61	50	35,5	24	17	0,16

DIMENSIONS (mm) – HVV					
SIZE	A	B	SW1	SW2	WEIGHT (kg)
3/8"	61	49	24	17	0,17

DIMENSIONS (mm) – AFZ				
SIZE	A	B	SW1	WEIGHT (kg)
3/8"	61	50	24	0,14

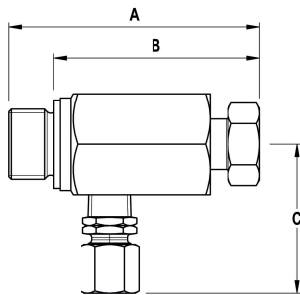

BDVL

MATERIALS		
POS. N°	DESIGNATION	MATERIAL
1	Body	AISI 303 / 1.4301
2	Valve screw	AISI 410 / 1.4301
3	Ball valve	AISI 440C / 1.4125
4	* Gasket	Stainless steel / Graphite; Copper / Stainless steel
5	Retaining ring	Spring steel
6	Compression fitting 1/8" x 6 mm	AISI 316 / 1.4401
6.1	Compression fitting 1/4" x 8 mm	AISI 316 / 1.4401
7	Spring	AISI 302 / 1.4310
8	Ball retainer	AISI 303 / 1.4305

\* Not applicable in NPT version.

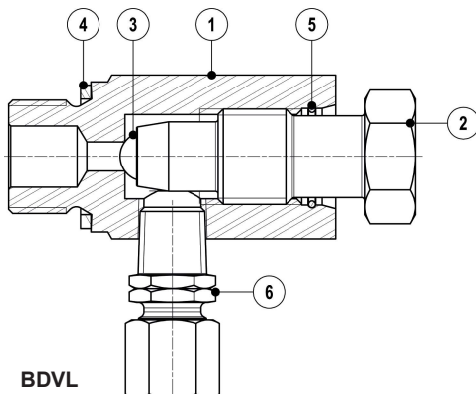

BDVL

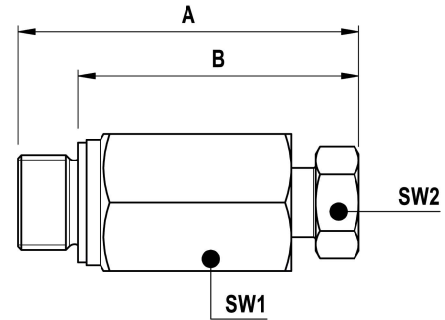

BDV / HVV

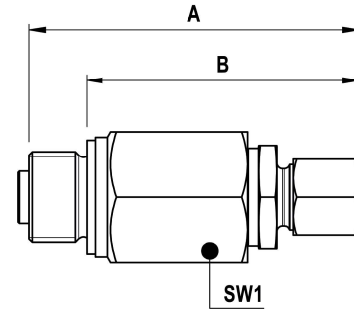

AFZ

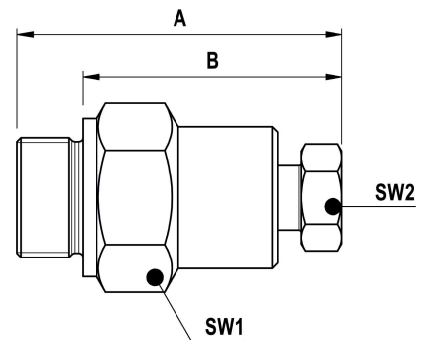

BDV-M22

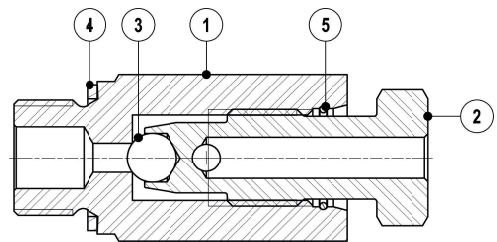

BDV

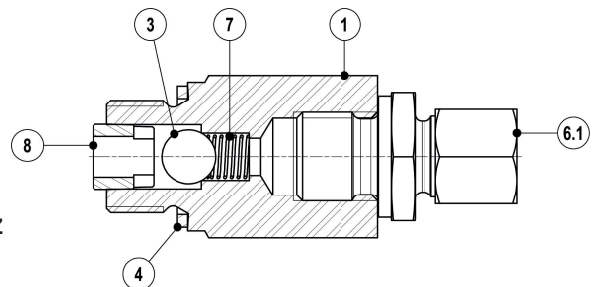

AFZ

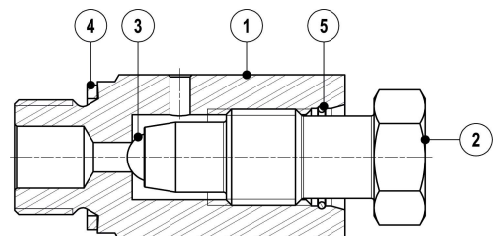

HVV