

PNEUMATIC CONTROL VALVES

PV40

(V40 globe valves series with linear actuators PA or EL series)

DESCRIPTION

The PV40 control valves are single seated, two-way body constructed with in-line straight connections. The PA pneumatic actuator is rubber diaphragm and multi-springs. Its action can be DA – direct action (air to close) or RA – reverse action (air to open). The PV40 valves have been designed to ensure an accurate control in any process condition. Their wide application ranges allow the use of this valve with the most common process fluids such as water, superheated water, steam, air, gas and other non corrosive fluids.

MAIN FEATURES

Single seated, two way, direct or reverse action valve.
Valve top flange permanently attached to the body, removal is unnecessary for replacing the actuator.
Metal to metal sealing as standard.



OPTIONS: Soft sealing.
Position transmitter.
Pneumatic pilot positioner.
Air filter regulator.
Top-work manual handwheel.

MAX.AIR SUPPLY: 3,5 bar.

AMBIENT TEMP.: -20 °C to 70 °C.

BONNET: Standard – up to 220 °C;
Extended finned – above 220 °C.

USE: Saturated and superheated steam.
Hot and superheated water.
Diathermic oil.
Air, gases and other no corrosive fluids.

STEM SEALING: PTFE/GR V-Rings – up to 220°C;
Graphite – up to 300°C.
Stainless steel bellows.

AVAILABLE MODELS: PV40S and EV40S – steel.
PV40I and EV40I – stainless steel.

PLUG CHARACT.: EQP – equal percentage;
PL – linear;
PT – on/off.

SIZES: 1/2" to 2"; DN 15 to DN 50.

PLUG DESIGN: Contoured;
Perforated (Low noise, anti-cavitation);
Microflow.

CONNECTION: Flanged EN 1092-1 PN 40.
Flanged ASME B16.5 Class 150 or 300.
Threaded connections on request.

PORT: Full or reduced on request.

PNEUMATIC ACTUATORS: PA205, PA280, PA340, PA435.

ACTUATOR CONN: 1/4" NPT-F.

CONTROL SIGNAL: 0,2 – 1bar; 0,4 – 1,2 bar; 0,4 – 2 bar.

ELECTRIC ACT.: Consult IS EL20.00 E.

CE MARKING – GROUP 2 (PED – European Directive)	
PN 40	Category
DN 15 to 32	SEP
DN 40 to 50	1 (CE Marked)

BODY LIMITING CONDITIONS				
V40S		V40I		RELATED TEMP.
FLANGED PN 40 *	FLANGED PN 40 *	FLANGED CLASS 300 **	FLANGED CLASS 300 **	
ALLOW. PRESSURE	RELATED TEMP.	ALLOW. PRESSURE	ALLOW. PRESSURE	
40 bar	50 °C	40 bar	39,9 bar	50 °C
33,3 bar	150 °C	37,9 bar	34,4 bar	100 °C
30,4 bar	250 °C	30 bar	26,6 bar	250 °C
27,6 bar	300 °C	27,6 bar	25,2 bar	300 °C

* Rating acc. to EN 1092-1:2018; ** Rating acc. to EN 1759-1:2004.
Remarks: Maximum temperatures limited to the valve packing selected.
Valves with soft seal, maximum allow. temp: 200 °C.
PN 63 and PN 100 designs on request.

DIMENSIONS (mm)

SIZE	A PN40	A CLASS 150	A CLASS 300	B	C - BONNET		
					STANDARD	FINNED	BELLOWS
1/2" – DN 15	150	184	190	71	75	140	267
3/4" – DN 20	150	184	194	71	75	140	267
1" – DN 25	160	184	197	71	75	140	267
1 1/4" – DN 32	180	–	–	75	83	163	285
1 1/2" – DN 40	200	222	235	82	96	163	285
2" – DN 50	230	254	267	97	100	182	298

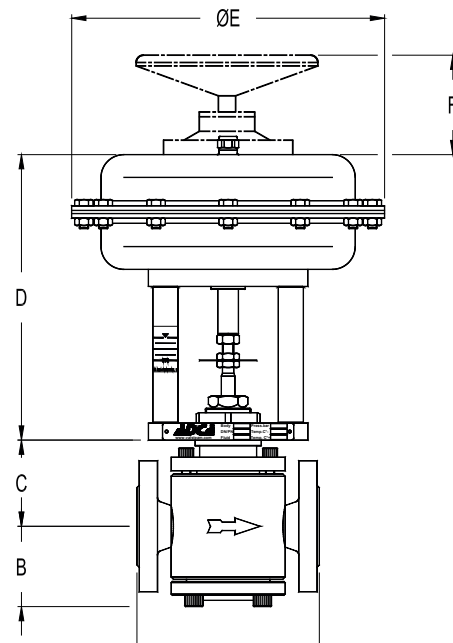
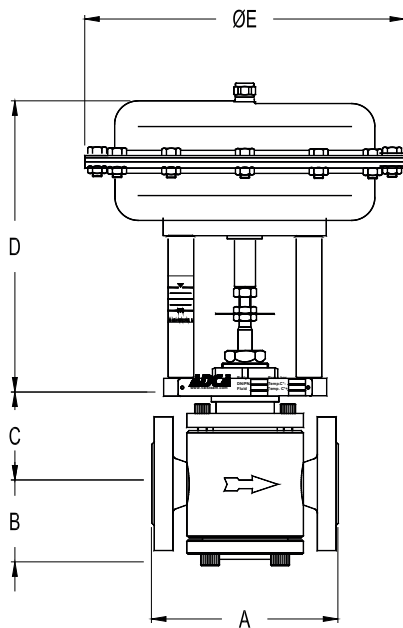

DIMENSIONS – PNEUMATIC ACTUATOR

TYPE	E (mm)	D (mm)	WEIGHT (kg)
PA205	210	235	6
PA280	275	245	10
PA340	335	265	15
PA435	430	295	25

MATERIALS

POS.	DESIGNATION	PV40S	PV40I
1	Valve body	S355JR / 1.0045	AISI 316 / 1.4401
2	Bonnet	A351 CF8 / 1.4308	A351 CF8 / 1.4308
3	Actuator (Steel)	S235JR / 1.0038	S235JR / 1.0038
	Actuator (Stainl. st.)	AISI 304 / 1.4301	AISI 304 / 1.4301
4	* Diaphragm	NBR 70	NBR 70
5	Yoke (Steel)	C45E / 1.1191	C45E / 1.1191
	Yoke (Stainl. St.)	AISI 304 / 1.4301	AISI 304 / 1.4301
6	* Valve plug	PTFE/GR; St. steel	PTFE/GR; St. steel
7	* Standard packing	PTFE/GR	PTFE/GR

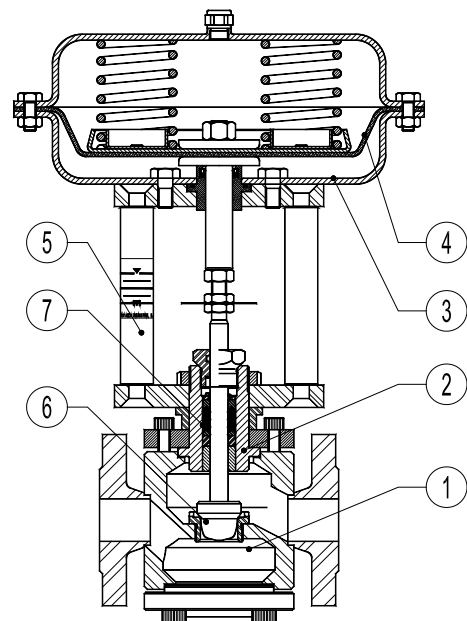

* Available spare parts.

For electric actuator materials and dimensions, consult IS EL 20.00 E.

VALVE STROKE (mm)						
TYPE	SIZES					
	DN 15	DN 20	DN 25	DN 32	DN 40	DN 50
STROKE	20					

FLOW RATE COEFFICIENTS						
TYPE	SIZES					
	DN 15	DN 20	DN 25	DN 32	DN 40	DN 50
Kvs	3,8	5,1	9,4	15,4	22,2	40,1

Kvs in m³/h, see IS PV10.00 E – Technical information;
 For conversion Kvs = Cv (US) x 0,855.

MAX. PERM. PRESSURE DROP (bar) – N.C. (fluid to open) – Reverse action actuator (air signal to open)							
ACTUATOR	CONTROL SIGNAL	SIZES					
		DN 15	DN 20	DN 25	DN 32	DN 40	DN 50
PA205	0,2 ÷ 1 bar	6	6	5	–	–	–
	0,4 ÷ 1,2 bar	10	10	7	–	–	–
	0,4 ÷ 2 bar	12	12	9	–	–	–
PA280	0,2 ÷ 1 bar	28	26	16	8	6	3,5
	0,4 ÷ 1,2 bar	40	38	20	12	10	5
	0,4 ÷ 2 bar	50	45	25	16	12	6,5
PA340A	0,2 ÷ 1 bar	60	60	50	20	12	10
	0,4 ÷ 1,2 bar	80	80	60	30	16	13
	0,4 ÷ 2 bar	100	100	80	40	20	18
PA435A	0,2 ÷ 1 bar	–	–	–	–	40	25
	0,4 ÷ 1,2 bar	–	–	–	–	48	30
	0,4 ÷ 2 bar	–	–	–	–	55	45

The pressure drop values are referred to closed valves. They have been verified by a control signal coming from an electro-pneumatic converter with an enduring minimum signal of 0,2 bar.
 The actuator press. drops given with closed valve for the actuator signal 0,4 - 2 bar are also valid for on/off service with air supply at 2,4 bar.
 Special spring drops available on request.
 The pressure drop values must be used within the body rating limits.
 For electric actuator selection please consult catalogue IS EL.20.00 E or our technical department.

MAX. PERM. PRESSURE DROP (bar) – N.O. (fluid to open) – Direct action actuator (air signal to close)							
ACTUATOR	CONTROL SIGNAL	SIZES					
		DN 15	DN 20	DN 25	DN 32	DN 40	DN 50
PA205	0,2 ÷ 1 bar	16	16	12	5	–	–
	0,4 ÷ 2 bar	25	24	16	7,5	–	–
PA280	0,2 ÷ 1 bar	–	–	19	10	8	4
	0,4 ÷ 2 bar	–	–	25	20	16	7
PA340A	0,2 ÷ 1 bar	–	–	–	17	16	10
	0,4 ÷ 2 bar	–	–	–	28	26	25

The actuator pressure drops given with closed valve, are obtained with the following air pressures supply:
 Actuator signal 0,2 to 1 bar : air supply 1,2 bar
 Actuator signal 0,4 to 2 bar : air supply 2,4 bar
 The actuator press. drops given with closed valve for the actuator signal 0,4- 2 bar are also valid for on/off service with air supply at 2,4 bar.
 Special spring drops available on request.
 The pressure drop values must be used within the body rating limits.
 For electric actuator selection please consult catalogue IS EL.20.00 E or our technical department.

ORDERING CODES V40										
VALVE CODES		P	V	.40S	1	1	A	15		
Actuator type										
Pneumatic actuator		P								
Electric actuator		E								
Group designation										
Globe valve, two way, straight body			V							
Valve model										
PN40 Steel body				.40S						
PN40 Stainless steel body				.40I						
Stem sealing										
PTFE/GR V-Rings / standard bonnet					1					
Virgin PTFE V-Rings / standard bonnet					2					
Graphite / standard bonnet					3					
Graphite / finned bonnet					4					
Stainless steel bellows					8					
Valve plug										
EQP (equal percentage) – Soft (PTFE/GR)						1				
EQP (equal percentage) – Metal AISI 316 / 1.4401						3				
EQP (equal percentage) – Stellite						4				
PL (linear) – Soft (PTFE/GR)						6				
PL (linear) – Metal AISI 316 / 1.4401						7				
PL (linear) – Stellite						8				
PT (on-off) – Soft (PTFE/GR)						9				
PT (on-off) – Metal AISI 316 / 1.4401						10				
PT (on-off) – Stellite						11				
Pipe connection										
Threaded ISO 7 Rp							A			
Flanged EN 1092-1 PN40							N			
Flanged ANSI B16.5 300 lb							V			
Size										
DN 15								15		
DN 20								20		
...										
Actuator										(1)
Extras										
Full description or additional codes have to be added in case of non-standard combination.										E

ACTUATOR CODES (PNEUMATIC) *					
VALVE CODES		P.	1	D	15
Group designation					
Multi-spring, pneumatic linear actuator		P.			
Actuator size					
205			1		
280			3		
340A – From DN 15 to DN 50			5		
435A – From DN 15 to DN 50			7		
Actuator type					
Direct action (air to close)				D	
Reverse action (air to open)				R	
Actuator Construction					
Steel construction (painted) – standard					(2)
Stainless steel construction				I	
Control signal					
0,2 – 1 bar (3/15 psi)					15
0,4 – 1,2 bar (6/18 psi)					18
0,4 – 2 bar (6/30 psi)					30

→ To be introduced on ".X.", if supplied in combination with the valve.

Example:

V40S valve model, EQP soft plug, PTFE/GR stem sealing, EN flanges, DN 15, complete with reverse action actuator signal 0,4 – 1,2 bar, size 340A steel:

Code: PV.40S11N50.5R18

REMARKS:

- (1) – Indicate actuator.
- (2) – Omitted if the standard valve is selected.

ADCATrol control valves are identified by a serial number on a nameplate, located on the actuator yoke. When ordering spares, always use that serial number. If the valve has non-standard extras the serial number has also an E (extras).

* For electric actuator ordering codes, consult our technical department.