

SANITARY PRESSURE REDUCING VALVE P163

DESCRIPTION

The ADCAPure P163 is a series of inline direct acting, diaphragm sensing pressure reducing valves. These regulators, available with spring or dome-loading, are designed for use with clean steam, compressed air, water and other gases or liquids compatible with the construction materials and valve design.

MAIN FEATURES

Spring or dome-loaded.
Non-rising adjustment knob.
Compact inline design with clamped body.
FDA / USP Class VI compliant seals.
Completely machined from bar stock material, no castings or forgings are used.

STANDARD SURFACE FINISH

Internal wetted parts: $\leq 0,51$ micron Ra – SF1.
External: $\leq 0,76$ micron Ra – SF3.
Other surface conditions see IS PV20.00 E – Technical information.
Ultrasonic cleaning.

OPTIONS:

- Leakage line connection 1/8" (captured vent).
- Different soft sealings for liquids and gases.
- Lock system, allows inline clean-in-place (CIP) and sterilization-in-place (SIP) operations.
- Gauge connection on body.
- Top cap (adjustment screw with cover).
- Bottom cover with drain connection.
- Dome-loaded version.

USE: Clean steam, compressed air, water and other gases and liquids compatible with the construction.

AVAILABLE MODELS: P163.

SIZES: 1/2" to 2"; DN 15 to 50.

REGULATING RANGES: 0,8 to 1,5 bar; 1 to 3 bar; 1,5 to 5 bar.

CONNECTIONS: ASME BPE, DIN and ISO clamp ferrules or tube weld (ETO) ends. Others on request.

PACKAGING: Assembling and packaging in a clean room certified according to ISO 14644-1. The product is end capped and sealed with recyclable thermo-shrinkable plastic film, to avoid contamination.

INSTALLATION: Horizontal installation. See IMI – Installation and maintenance instructions.



LIMITING CONDITIONS

Valve model	P163
Body design conditions	PN 16
Maximum upstream pressure	8 bar
Maximum downstream pressure	5 bar
Minimum downstream pressure *	0,8 bar
Maximum operating temperature **	180 °C

* For tight shut off, with adjustment spring relaxed, ensure a minimum downstream pressure of 0,2 bar.
** With PTFE diaphragm and seals. Consult the manufacturer in case of other elastomer materials.

CE MARKING – GROUP 2 (PED – European Directive)

PN 16	Category
1/2" to 2" – DN 15 to 50	SEP

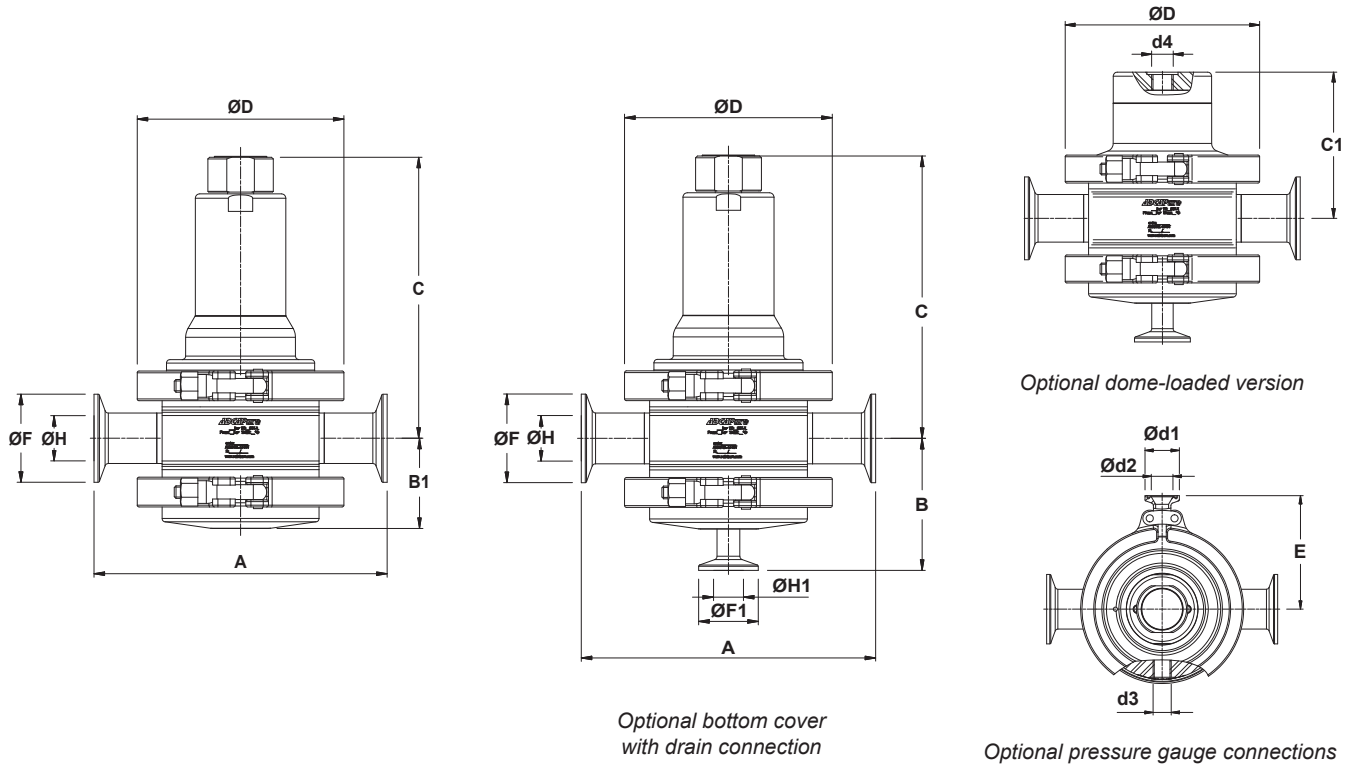

DIMENSIONS (mm) ASME BPE

SIZE	A	B	B1	C	C1	D	d1	d2	d3 *	d4 *	E	F	H	F1	H1	WGT. (kg)
1/2"	153	70	47	156	84	119	25	15,75	1/4"	1/4"	83	25	9,4	25	9,4	5
3/4"	153	74	51	160	88	119	25	15,75	1/4"	1/4"	83	25	15,75	25	9,4	5,6
1"	153	77	54	163	91	119	25	15,75	1/4"	1/4"	83	50,5	22,1	25	9,4	5,7
1 1/2"	170	95	71	204	124	134	25	15,75	1/4"	1/4"	96	50,5	34,8	25	9,4	9,8
2"	170	99	74	207	127	134	25	15,75	1/4"	1/4"	96	64	47,5	25	9,4	9,8

DIMENSIONS (mm) DIN

SIZE	A	B	B1	C	C1	D	d1	d2	d3 *	d4 *	E	F	H	F1	H1	WGT. (kg)
DN 15	153	74	51	160	88	119	25	15,75	1/4"	1/4"	83	34	16	34	10	5,6
DN 20	153	72	49	158	86	119	25	15,75	1/4"	1/4"	83	34	20	34	10	5,3
DN 25	168	75	52	161	89	119	25	15,75	1/4"	1/4"	83	50,5	26	34	10	5,6
DN 32	168	77	54	163	91	119	25	15,75	1/4"	1/4"	83	50,5	32	34	10	5,8
DN 40	185	94	70	202	122	134	25	15,75	1/4"	1/4"	96	50,5	38	34	10	9,5
DN 50	185	98	74	206	126	134	25	15,75	1/4"	1/4"	96	64	50	34	10	9,8

Remarks: Clamp ferrules according to DIN 32676-A; Tube weld (ETO) according to DIN 11866-A (DIN 11850-2).

DIMENSIONS (mm) ISO

SIZE	A	B	B1	C	C1	D	d1	d2	d3 *	d4 *	E	F	H	F1	H1	WGT. (kg)
DN 15	168	73	50	159	87	119	25	15,75	1/4"	1/4"	83	50,5	18,1	25	10,3	5,4
DN 20	168	76	53	162	90	119	25	15,75	1/4"	1/4"	83	50,5	23,7	25	10,3	5,6
DN 25	168	78	55	164	92	119	25	15,75	1/4"	1/4"	83	50,5	29,7	25	10,3	6
DN 32	185	93	69	202	122	134	25	15,75	1/4"	1/4"	96	64	38,4	25	10,3	9,6
DN 40	185	100	76	206	126	134	25	15,75	1/4"	1/4"	96	64	44,3	25	10,3	10

Remarks: Clamp ferrules according to DIN 32676-B; Tube weld (ETO) according to DIN 11866-B (ISO 1127).

* As standard, optional connections d3 and d4 are female threaded ISO 7 Rp.

FLOW RATE COEFFICIENTS (m³/h)																
	ASME BPE					DIN						ISO				
SIZE	1/2"	3/4"	1"	1 1/2"	2"	DN 15	DN 20	DN 25	DN 32	DN 40	DN 50	DN 15	DN 20	DN 25	DN 32	DN 40
Kvs	1,3	3	4,2	7	13	2,1	3	4,2	4,2	7	13	2,1	4,2	4,2	7	7

MATERIALS		
POS. N°	DESIGNATION	MATERIAL
1	Valve body	AISI 316L / 1.4404
2	Cover	AISI 316L / 1.4404
2A	Bottom cover	AISI 316L / 1.4404
3	Intermediate flange	AISI 316L / 1.4404
3A	Clamp	AISI 316 / 1.4401
3B	Gasket	FKM / PTFE
4	* Valve stem	AISI 316L / 1.4404
5	* Soft plug	EPDM
6	* Valve plug	AISI 316L / 1.4404
7	* Upper diaphragm	EPDM
8	* Lower diaphragm	Gylon 3522
9	Diaphragm plate	AISI 316L / 1.4404
10	* O-ring	EPDM
11	Diaphragm plate	AISI 316L / 1.4404
12	Stem guide	AISI 316L / 1.4404
12A	Plain bearing	Bronze
12B	Spring	AISI 302 / 1.4300
13	Spring plate	AISI 316L / 1.4404
14	Nut	AISI 304 / 1.4301
15	Washer	AISI 304 / 1.4301
16	* Adjustment spring	AISI 302 / 1.4300
17	Top spring plate	AISI 316L / 1.4404
18	Retaining washer	Stainless steel A2-70
19	Adjustment nut	AISI 316L / 1.4404
20	Adjustment screw	Brass
21	O-ring	NBR
22	Bearing	Corrosion resistant steel
23	Ext. bowed shaft ring	Stainless steel
24	Cover nut	Plastic
25	* O-ring	EPDM

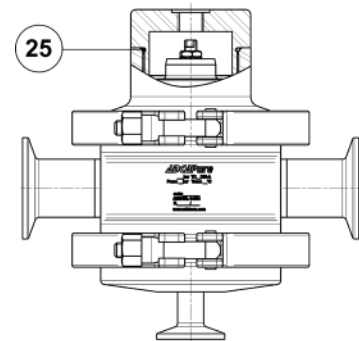
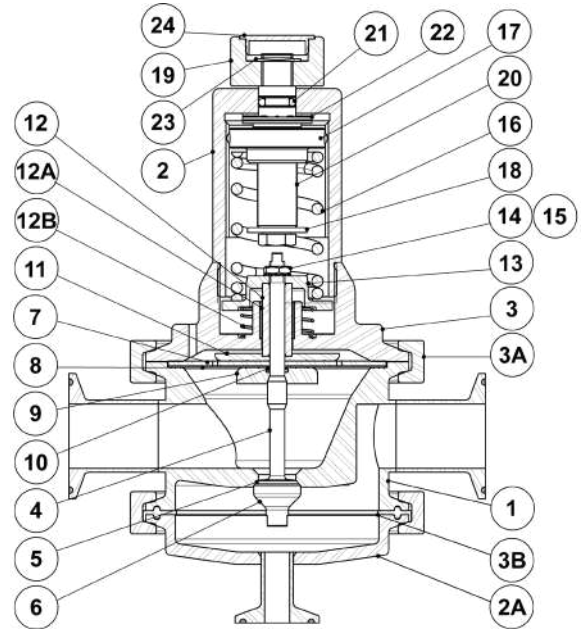

Optional dome-loaded version

* Available spare parts; ** Others according to fluid.

Remarks: FDA / USP Class VI seals certificate on request.

All valves have a serial number. In case of non-standard valves, this number must be supplied if spare parts are ordered.

OPTIONS			
LOCK SYSTEM	ADJUSTMENT SCREW WITH TOP CAP	PRESSURE GAUGE CONNECTION	LEAKAGE LINE CONNECTION

ORDERING CODES P163

Valve model	P63	1	4	1	T	M	I	X	X	X	DI	15	E
P163 – AISI 316L / 1.4404 diaphragm sensing press. reducing valve without drain	P63												
P163 – AISI 316L / 1.4404 diaphragm sensing press. reducing valve with drain	P63D												
Valve series													
Series 1		1											
Regulating range													
0,8 to 1,5 bar			4										
1 to 3 bar			5										
1,5 to 5 bar			6										
0,8 to 5 bar (dome-loaded) a)			A										
Flow rate coefficient													
Kvs 1,3 (only applicable to ASME BPE 1/2" size)		1											
Kvs 2,2 (applicable to sizes DIN DN 15 and ISO DN 15)		2											
Kvs 3 (applicable to sizes ASME BPE 3/4" and DIN DN 20)		3											
Kvs 4,2 (applicable to sizes ASME BPE 1", DIN DN 25 to DN 32 and ISO DN 20 to DN 25)		4											
Kvs 7 (applicable to sizes ASME BPE 1 1/2", DIN DN 40 and ISO DN 32 to DN 40)		6											
Kvs 13 (applicable to sizes ASME BPE 2" and DIN DN 50)		8											
Diaphragm													
PTFE (Gylon)					T								
EPDM (non-standard)					E								
Seat material b)													
Metal to metal (non-standard, except in ASME BPE 1/2" size)						M							
EPDM						E							
PTFE						T							
FPM / Viton (FDA approval only)						V							
Adjustment knob, top cap and captured vent													
Stainless steel adjustment knob							I						
Top cap (adjustment screw with cover)							T						
Stainless steel adjustment knob w/ diaphragm cover leakage connection in case of diaphragm failure							L						
Top cap (adjustment screw with cover) w/ diaphragm cover leakage connection in case of diaphragm failure							U						
Dome-loaded top c)							X						
Gauge port options													
Without gauge ports								X					
Tri-clamp gauge port on the left side (rel. to the flow direction) – downstream pressure								7					
Tri-clamp gauge port on the right side (rel. to the flow direction) – downstream pressure								6					
Tri-clamp gauge port on both sides – downstream pressure								5					
Threaded gauge port on the left side (rel. to the flow direction) – downstream pressure – ISO 7 Rp 1/4"								4					
Threaded gauge port on the right side (rel. to the flow direction) – downstream pressure – ISO 7 Rp 1/4"								3					
Threaded gauge port on both sides – downstream pressure – ISO 7 Rp 1/4"								2					
Threaded gauge port on the left side (rel. to the flow direction) – downstream pressure – 1/4" NPT								W					
Threaded gauge port on the right side (rel. to the flow direction) – downstream pressure – 1/4" NPT								Y					
Threaded gauge port on both sides – downstream pressure – 1/4" NPT								Z					
Surface finish d)													
Standard surface finish									X				
Mirror mechanical polished external surfaces (SF1)									P				
Electropolished internal wetted parts (SF5)									E				
Special features													
None										X			
Degreased for oxygen										O			
CIP / SIP lock system										C			
Pipe connections													
Clamp ferrule ASME BPE												D	
Clamp ferrule DIN (DIN 32676-A)												F	
Clamp ferrule ISO (DIN 32676-B)												E	
Tube weld (ETO) according to ASME BPE												DI	
Tube weld (ETO) according to DIN 11866-A (DIN 11850-2)												FI	
Tube weld (ETO) according to DIN 11866-B (ISO 1127)												EI	
Size													
1/2" or DN 15												15	
3/4" or DN 20												20	
1" or DN 25												25	
DN 32												32	
1 1/2" or DN 40												40	
2" or DN 50												50	
Special valves / Extras													
Full description or additional codes have to be added in case of a non-standard combination													E

a) The loading control pressure can be up to a maximum of 0,2 bar above the required downstream pressure; b) ASME BPE 1/2" size is only available with metal to metal sealing; c) Must be chosen in case of dome-loaded version; d) Consult IS PV20.00 – Technical information – for further details and other surface finish options.