

TEMPERATURE REGULATORS SELF ACTING, NON BALANCED, SINGLE SEAT TR25S

DESCRIPTION

The TR25 series of temperature regulators were designed for direct acting temperature control systems where the valve closes on temperature rise. They are single seated and are intended to be coupled with T series thermostat models T.205 and T.405. The liquid filling the thermostat expands when the temperature of the fluid being heated rises, closing the valve.

These valves are used for controlling temperature in central and district heating systems, heat exchangers and other HVAC and industrial applications

MAIN FEATURES

- Easily adjustable temperature range.
- Proportional temperature control.
- Single seated, two way, direct acting valve.
- Leakage < 0,05% Kvs.
- Built-in strainer.
- Narrow thermostat neutral zone (1,5 °C - 2,5 °C).
- No special tools required for servicing.
- Stuffing box is an integral part of the thermostatic element, allowing easy and simple maintenance of the valve.

- OPTIONS:**
- PK sensor pocket.
 - K1 cooling unit.
 - Different capillary lengths.
 - Other thermostats on request.

- USE:**
- Saturated and superheated steam.
 - Hot and superheated water.

- AVAILABLE VALVES:**
- TR25S – carbon steel.

- AVAILABLE THERMOSTATS:**
- T.205 – 200 N (max. closing force).
 - T.405 – 400 N (max. closing force).

- SIZES:**
- 1/2" to 1".

- CONNECTIONS:** Female threaded ISO 7 Rp.
- THERMOSTAT RANGES:**
- T.205: 0 – 60 °C, 30 – 90 °C and 60 – 120 °C.
 - T.405: 0 – 120 °C and 40 – 160 °C.

- INSTALLATION:**
- Horizontal installation with the thermostat in the vertical position, in order to reduce wear. In case of medium temperatures up to 150 °C, the thermostat may be fitted below or above the valve. In case of medium temperatures between 150 and 250 °C, a cooling unit type K1 has to be applied with the connection pointing downwards. A "Y" strainer should be installed upstream of the valve. See IMI – Installation and maintenance instructions.

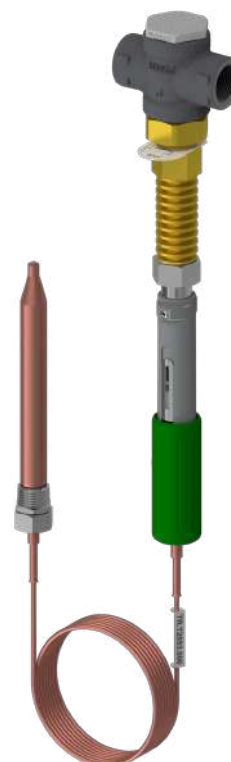

PK sensor pocket

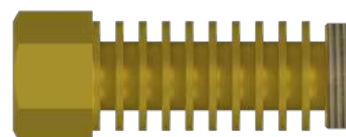

K1 cooling unit

BODY LIMITING CONDITIONS	
PN 40 ALLOWABLE PRESSURE	RELATED TEMPERATURE
40 bar	120 °C
24 bar	350 °C

Minimum working temperature: -10 °C.

TECHNICAL DATA				
TYPE	CONNECTION	OPENING Ø	Kvs (m³/h)	STROKE
TR25 – 15/4	DN 15	4 mm	0,2	6 mm
TR25 – 15/6	DN 15	6 mm	0,45	6 mm
TR25 – 15/9	DN 15	9 mm	0,95	6 mm
TR25 – 15/12	DN 15	12 mm	1,7	6 mm
TR25 – 15/15	DN 15	15 mm	2,75	6 mm
TR25 – 20/9	DN 20	9 mm	0,95	6,5 mm
TR25 – 20/15	DN 20	15 mm	2,75	6,5 mm
TR25 – 20/20	DN 20	20 mm	5	6,5 mm
TR25 – 25/20	DN 25	20 mm	5	7 mm

MAX. PERMISSIBLE DIFFERENTIAL PRESSURES			
SIZE	SEAT Ø	T.205	T.405
		DIFFERENTIAL PRESSURE	DIFFERENTIAL PRESSURE
DN 15	4 and 6 mm	21 bar	40 bar
DN 15	9 mm	13 bar	38 bar
DN 15	12 mm	9,3 bar	24 bar
DN 15	15 mm	5,3 bar	15 bar
DN 20	15 mm	5,3 bar	15 bar
DN 20	20 mm	2,9 bar	9 bar
DN 25	20 mm	2,9 bar	9 bar

PROPORTIONAL BAND

The proportional band is the temperature change required for the valve to move from its fully open to fully closed position. It depends on the valve stroke (mm) and on the thermostat movement per °C (mm/°C), and is calculated as follows:

Proportional band:
$$\frac{\text{Valve stroke (mm)}}{\text{Thermostat mov. (mm/°C)}}$$

Thermostat movement for T.205 and T.405: 0,5 mm/°C

A proportional band between 8 °C and 13 °C is suitable for most applications. A smaller proportional band is not ideal when heat loads vary rapidly.

DIMENSIONS (mm) – THERMOSTAT					
TYPE	A	B	C	E	WEIGHT (kg)
T.205	305	405	210	22	1,8
T.405	385	525	390	22	2,6

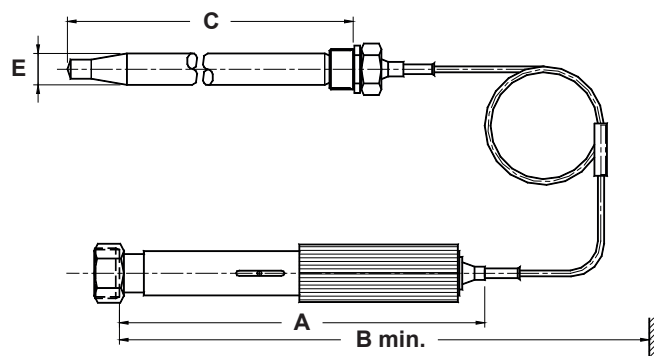

DIMENSIONS (mm) – VALVE BODY					
SIZE	A	B	C	F	WEIGHT (kg)
1/2"	90	40	70	50	1,2
3/4"	90	40	70	50	1,2
* 3/4"	100	45	75	55	1,6
1"	100	45	75	55	1,6

* TR25 – 20/20 model only.

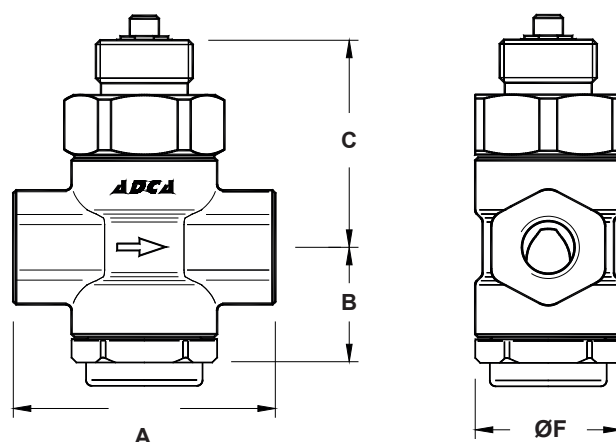

MATERIALS		
POS. N°	DESIGNATION	MATERIAL
1	Body	P250GH / 1.0460
2	Bonnet	CK45 / 1.1191
3	* Gasket	St. steel / Graphite
4	* Valve plug	AISI 316 / 1.4401
5	Seat	AISI 316 / 1.4401
6	* Spring	AISI 302 / 1.4300
7	Cap	CK45 / 1.1191
8	* Strainer screen	AISI 304 / 1.4301
9	* Cap gasket	St. steel / Graphite

* Available spare parts.

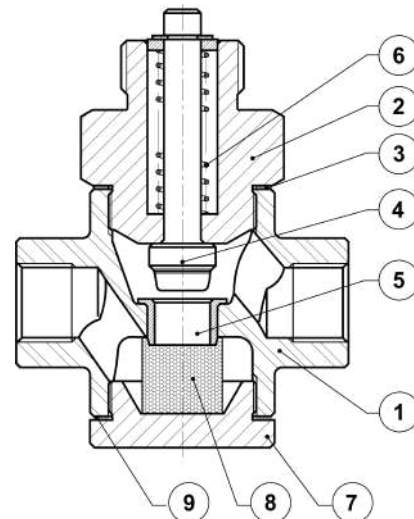

K1 COOLING UNITS

Cooling units are used as a means of protection for the stuffing box when dealing with high temperatures. The K1 cooling unit should always be applied when medium temperatures are between 150 °C and 250 °C. For higher temperatures as well as for all hot oil systems please consult.

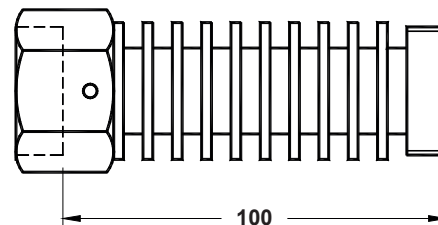

PK SENSOR POCKETS

Sensor pockets made of stainless steel can be supplied with all TR series self-acting thermostats using rod sensors. A sensor pocket, also called thermowell, is used to protect the sensor and to allow its removal while the plant is running or, e.g., the tank where it is connected to is full. The use of sensor pockets implies delay of heat transfer to the rod sensors and, thus, a longer thermostat reaction time. This is, to some extent, counteracted by filling up the sensor pockets with a thermal conductive paste or glycerine.

INSTALLATION

The installation site for the sensor pocket is arbitrary when paste is applied. When glycerine is used, the sensor pocket must point at least slightly downwards.

MATERIAL

AISI 316 / 1.4401.

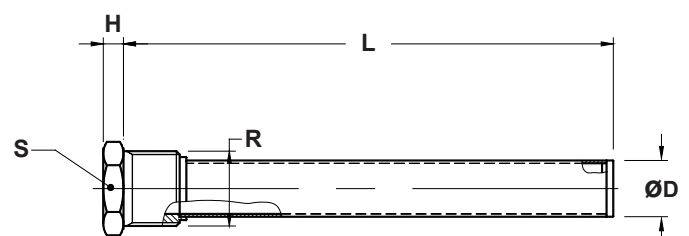

DIMENSIONS (mm)					
TYPE	D	H	L	S	R
PK2	25	9	218	36	1"
PK4	25	10	390	45	1 1/4"