

AUTOMATIC AIR AND GAS VENTS FOR LIQUID SYSTEMS

AE50i

(Stainless steel 1/2" x 1/2" to 1" x 1/2"; DN 15 x 1/2" to DN 25 x 1/2")

DESCRIPTION

The AE50 range of automatic vents are designed to remove air or gases from water and other liquid systems, without requiring any external source of energy.

They are capable of handling significant loads during start-up while still being able to discharge smaller loads in continuous modulating operation with one single orifice.

These ball float type vents are manufactured in stainless steel, available with soft sealing, and can be used in combination with other air elimination and separation systems or directly applied at high points in the pipelines.

MAIN FEATURES

Suitable for start-up and continuous operation with one single orifice.

Allow fast and easy inline maintenance.

Corrosion resistant internal parts.

No balancing pipe required.

OPTIONS: Different soft sealing options.
Metal to metal sealing.

USE: Cold, hot and superheated water or other liquids compatible with the construction.

AVAILABLE MODELS: AE50i – stainless steel.

SIZES: 1/2" x 1/2", 3/4" x 1/2" and 1" x 1/2";
DN 15 x 1/2", DN 20 x 1/2" and DN 25 x 1/2".

CONNECTIONS: Female threaded ISO 7 Rp or NPT.
Flanged EN 1092-1 PN 40.
Flanged ASME B16.5 Class 150 or 300.

INSTALLATION: Vertical installation.
It must be installed absolutely vertically at the points in the plant where the air tends to collect.
The drain should be piped to a safe location.
See IMI – Installation and maintenance instructions.



CE MARKING – GROUP 2 (PED – European Directive)

PN 40	Category
All sizes	SEP

BODY LIMITING CONDITIONS		
FLANGED PN 40 / CLASS 300	FLANGED CLASS 150 *	RELATED TEMP.
ALLOW. PRESS.	ALLOW. PRESS.	
30 bar	13,3 bar	100 °C
28,8 bar	11,1 bar	200 °C
26,6 bar	10,2 bar	250 °C
25,2 bar	9,7 bar	300 °C

PMO – Maximum operating pressure: 30 bar.

TMO – Maximum operating temperature:

Metal to metal sealing: 250 °C;

EPDM valve sealing: 130 °C;

FPM / Viton valve sealing: 200 °C.

Min. liquid specific weight: 0,75 kg/dm³.

* According to EN 1759-1:2004.

Body limiting conditions PN 40 or below, depending on the type of connection adopted. Rating PN 40 for threaded versions.

FLOW RATE CAPACITY (NL/min)																		
MODEL	DIFFERENTIAL PRESSURE (bar)																	
	0,5	1	2	3	4	5	6	7	8	9	10	12	15	18	20	22	25	30
AE50i	31	46	72	96	120	144	168	192	216	241	265	313	385	457	505	553	626	746

Values shown refer to capacities of air discharge at 15 °C, under average atmospheric pressure (1013 mbar).

If the temperature of the air differs from 15 °C, the discharge capacity can be corrected by multiplying it by: $\frac{288}{273 + T}$, where T is the actual temperature in °C.

It may be assumed that the temperature of the air is equal to the temperature of the water.

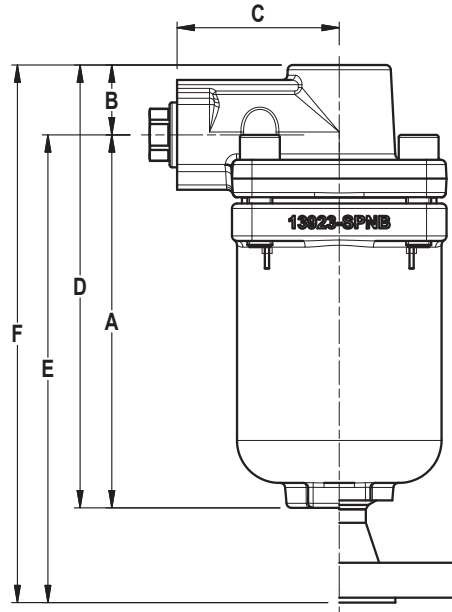

DIMENSIONS (mm)															
INLET	THREADED					PN 40			CLASS 150			CLASS 300			
SIZE	A	B	C	D	WGT. (kg)	E	F	WGT. (kg)	E	F	WGT. (kg)	E	F	WGT. (kg)	
1/2" x 1/2" – DN 15 x G 1/2"	149	28	65	177	3,6	187	215	4,4	197	225	4,1	202	230	4,4	
3/4" x 1/2" – DN 20 x G 1/2"	149	28	65	177	3,6	189	217	4,7	202	230	4,3	207	235	4,9	
1" x 1/2" – DN 25 x G 1/2"	149	28	65	177	3,6	189	217	4,8	205	233	4,6	211	239	5,2	

Remarks: As standard, in versions with EN flanged or female Rp threaded inlets, the outlet is female threaded ISO 228. In versions with ASME flanged or female NPT threaded inlets, the outlet is female threaded NPT.

MATERIALS		
POS. N°	DESIGNATION	MATERIAL
1	Body	AISI 316L / 1.4404
2	Cover	A351 CF8M / 1.4408
3	* Seat	AISI 316L / 1.4404
4	Mechanism support	AISI 304 / 1.4301
5	* Lever	AISI 304 / 1.4301
6	* Valve	AISI 316 / 1.4401; EPDM; Viton
7	* Float	AISI 316Ti / 1.4571
8	Bolt	Stainless steel A2-70
9	* Gasket	Stainless steel / Graphite
10	Bolts	Stainless steel A2-70
11	Plug	AISI 316L / 1.4404
12	** Washer	Copper

* Available spare parts; ** Not applicable in NPT version.

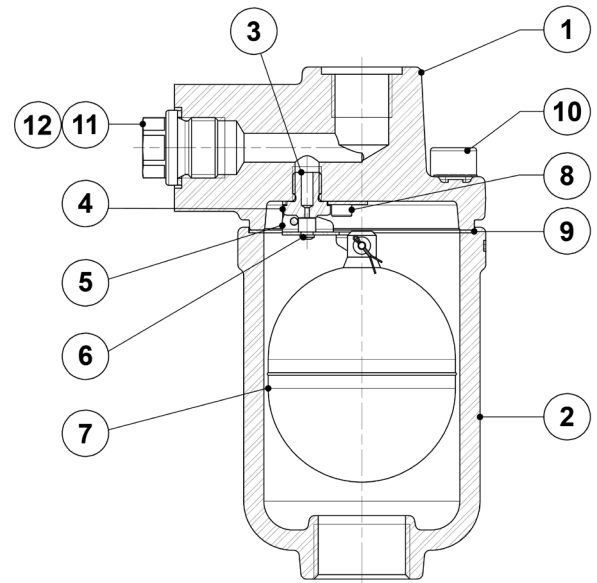

FLOW DIRECTION

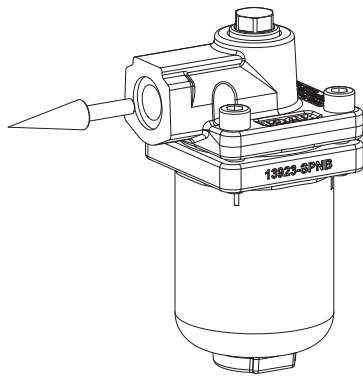

VF - Vertical inlet / straight front outlet

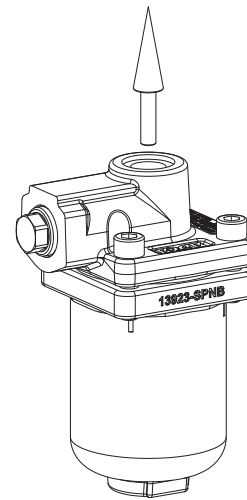

VT - Vertical from bottom to top

ORDERING CODES AE50i											
Model	AE50i	6	M	XX	VF	A	15	A	15	E	
AE50i – stainless steel	AE50i										
Differential pressure											
30 bar		6									
Valve sealing											
Metal to metal			M								
EPDM			E								
FPM / Viton			V								
Options											
None				XX							
Flow direction											
Vertical inlet / straight front outlet					VF						
Vertical from bottom to top					VT						
Outlet pipe connection											
Female threaded ISO 228						B					
Female threaded NPT						C					
Outlet size											
1/2"							15				
Inlet pipe connection											
Female threaded ISO 7 Rp								A			
Female threaded NPT								C			
Flanged EN 1092-1 PN 40								N			
Flanged ASME B16.5 Class 150								U			
Flanged ASME B16.5 Class 300								V			
Inlet size											
1/2" or DN 15										15	
3/4" or DN 20										20	
1" or DN 25										25	
Special valves / Extras											
Full description or additional codes have to be added in case of a non-standard combination											E