

NON-RETURN VALVES RT25

DESCRIPTION

The RT25 all stainless steel disc check valves have a compact design and were specially designed for use with steam and hot condensate.

MAIN FEATURES

Low pressure drop.
 Simple and compact design.

OPTIONS: Various soft sealing options:
 EPDM (E), NBR (N), VITON (V), PTFE (T).
 Inconel springs.

USE: Saturated steam, water and other gases compatible with the construction.

AVAILABLE MODELS: RT25 – stainless steel.

SIZES: 1/4" to 2".

CONNECTIONS: Female threaded ISO 7 Rp or NPT.

INSTALLATION: Horizontal or vertical installation.
 See IMI – Installation and maintenance instructions.



RECOMMENDED LIMITS OF OPERATION WITH SOFT SEALS			
EPDM (E)	NBR (N)	VITON (V)	PTFE (T)
130 °C	95 °C	180 °C	180 °C

CE MARKING – GROUP 2 (PED – European Directive)	
PN 25	Category
1/4" to 1 1/2"	SEP
2"	1 (CE marked)

LIMITING CONDITIONS	
Body design conditions	PN 25
Maximum allowable pressure	25 bar
Maximum allowable temperature	250 °C
Maximum operating pressure	21 bar
Maximum operating temperature	220 °C

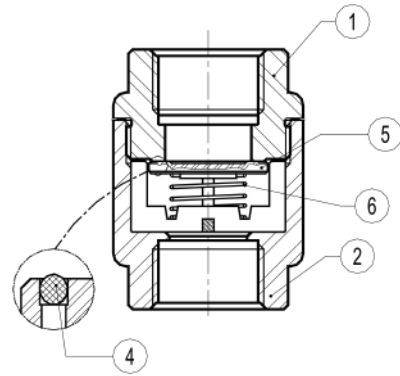
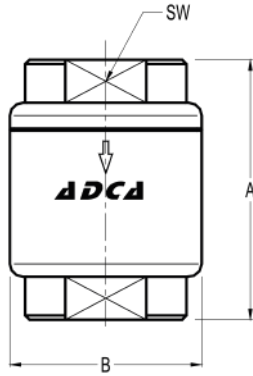

DIMENSIONS				
SIZE	A	B	SW	WEIGHT (kg)
1/4"	55	40	27	0,3
3/8"	55	40	27	0,3
1/2"	55	40	27	0,3
3/4"	60	45	32	0,38
1"	70	50	41	0,54
1 1/4"	61	65	50	0,68
1 1/2"	72	80	55	0,96
2"	72	80	70	1,13

MATERIALS		
POS. N°	DESIGNATION	MATERIAL
1	Body	AISI 316 / 1.4401
2	Cover	AISI 316 / 1.4401
4	* Soft seal	EPDM; NBR; VITON; PTFE
5	* Valve disc	AISI 316 / 1.4401
6	* Spring	AISI 302 / 1.4300

* Available spare parts.

MINIMUM OPENING PRESSURES WITH STANDARD SPRING (mbar)							
SIZE	D.P. ↑	D.P. →	D.P. ↓	D.P. * ↑			
1/4"	25	23	21	2			
3/8"	25	23	21	2			
1/2"	25	23	21	2			
3/4"	25	23	21	2			
1"	25	23	21	2			
1 1/4"	25	24	21	3			
1 1/2"	28	25	21	4			
2"	29	25	21	4			

→ : Flow direction.

* Vertical installation without springs (bottom to top).

Pressure drop, horizontal flow, standard spring (water - 20°)

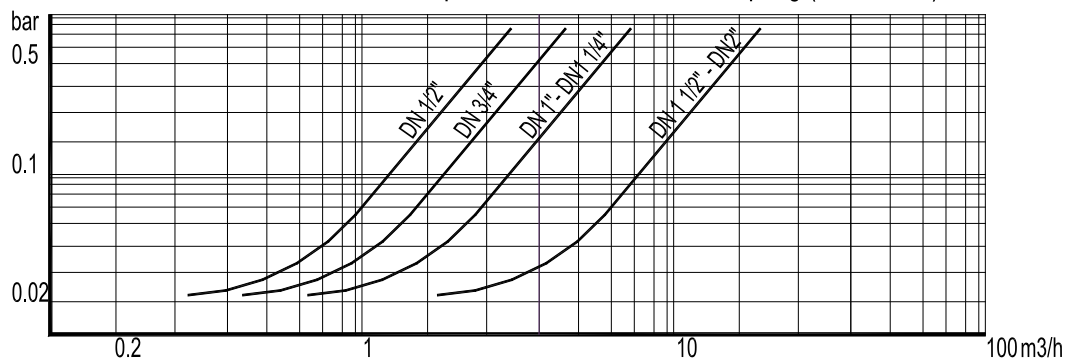

To determine the pressure drop of other mediums the equivalent water flow volume has to be calculated:

$$V_w = \sqrt{\frac{Q}{1000}} \times V$$

V_w = Equivalent water flow volume in m³/h; Q = Density in kg/m³; V = Flow volume in m³/h