

WAFER-TYPE NON-RETURN VALVE RD40 DN 125 – DN 200

DESCRIPTION

The RD40 disc check valves have a compact design and are specially designed for use with steam and hot condensate.

MAIN FEATURES

Low pressure drop.
Simple and compact design.
Overall lengths according to DIN EN 558-1 (DIN 3202 part 3, series K4).

OPTIONS: Various soft sealing options:
EPDM (E), NBR (N), VITON (V), PTFE (T).
Inconel springs.

USE: Saturated steam, water and other gases and liquids compatible with the construction.

AVAILABLE MODELS: RD40 – carbon steel body, stainless steel disc and seat.

SIZES: 5" to 8"; DN 125 to DN 200.

CONNECTIONS: Sandwiched between flanges as per EN 1092 or ASME.

INSTALLATION: Horizontal or vertical installation.
See IMI – Installation and maintenance instructions.



RECOMMENDED LIMITS OF OPERATION WITH SOFT SEALS			
--	--	--	--

EPDM (E)	NBR (N)	VITON (V)	PTFE (T)
130 °C	95 °C	180 °C	180 °C

CE MARKING – GROUP 2 (PED – European Directive)	
---	--

PN 40	Category
DN 125 to 200	2 (CE marked)

BODY LIMITING CONDITIONS	
--------------------------	--

WAFER PN 40 *	
ALLOWABLE PRESSURE	RELATED TEMPERATURE
40 bar	100 °C
33,7 bar	200 °C
31,8 bar	250 °C
29,7 bar	300 °C

* According to EN 1092.
Minimum operating temperature: - 10 °C.

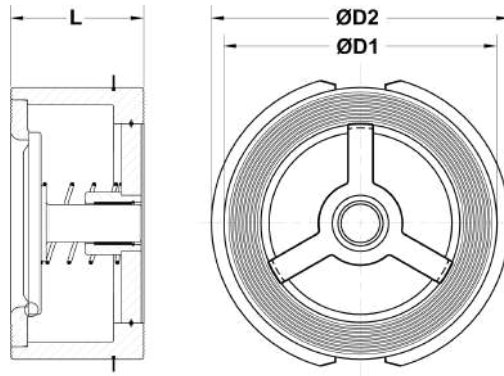

DIMENSIONS							
SIZE	PN 10/16	PN 40		CLASS 150	CLASS 300	L	WEIGHT (kg)
	D1	D1	D2 *	D1	D2 *		
5" – DN 125	192	192	-	192	212	90	10
6" – DN 150	218	-	226	218	247	106	14
8" – DN 200	273	-	290	273	304	140	24

* Centering ring required

MATERIALS		
POS. N°	DESIGNATION	MATERIAL
1	Body	S355JR / 1.0045
2	Seat	AISI 316 / 1.4401
3	* Disc	AISI 316 / 1.4401
4	* Spring	AISI 302 / 1.4300
5	Centering ring	AISI 304 / 1.4301
6	Bearing	Steel Fe Zn
7	Star	S355JR / 1.0045
8	* Soft seal	EPDM; NBR; VITON; PTFE

* Available spare parts.

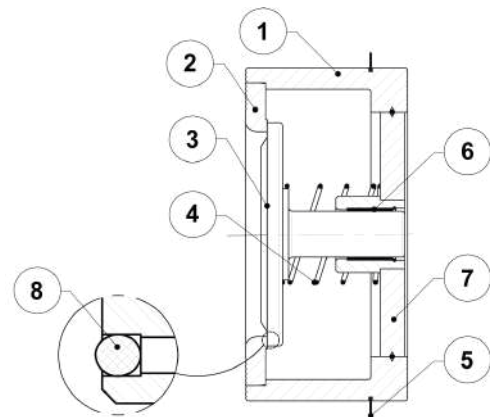

MINIMUM OPENING PRESSURES WITH STANDARD SPRING (mbar)						
SIZE	↑		→		↓	
	D.P.	D.P.	D.P.	D.P.	D.P.	D.P.
5" – DN 125	37	22	22	7	7	7
6" – DN 150	40	25	25	10	10	10
8" – DN 200	46	28	28	10	10	10

→ : Flow direction.

Pressure drop, horizontal flow, standard spring (water – 20°)

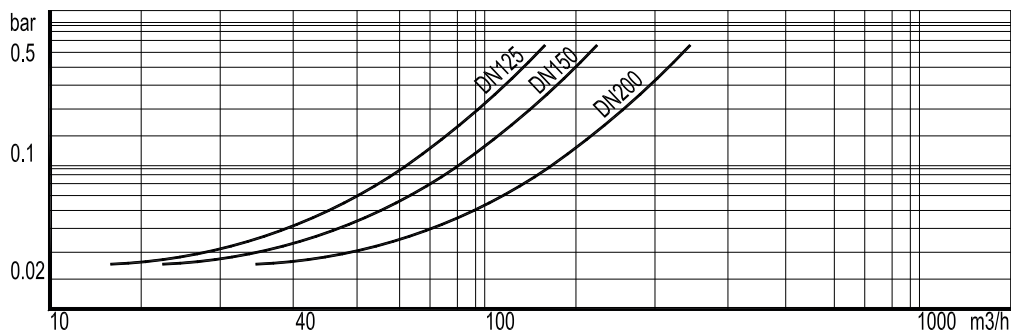

To determine the pressure drop of other mediums the equivalent water flow volume has to be calculated: $V_w = \sqrt{\frac{Q}{1000}} \times V$

V_w = Equivalent water flow volume in m³/h; Q = Density in kg/m³; V = Flow volume in m³/h