

## PRESSURE OPERATED PUMP POPS

### DESCRIPTION

The ADCAMat POP pressure operated pump, fabricated in carbon steel (stainless steel on request), is recommended in the transfer of high temperature liquids such as condensate, oils and others, to a higher elevation or pressure.

Under certain conditions, it can drain a closed vessel under vacuum or pressure.

The pump can be operated by steam, compressed air or other gases, and can be used for lifting any kind of non-corrosive liquids.



### OPERATION

Liquid flows by gravity into the pump through an inlet check valve lifting a float which, at the upper limit of its stroke, opens the supply valve, allowing steam or compressed air to enter the pump's body. Pressure in the pump builds up until it's just sufficient to overcome back pressure.

The pressurized liquid opens the outlet check valve and discharge begins. When the float reaches the minimum lower level, it closes the steam or compressed air supply valve and opens the vent, allowing the liquid to fill the pump again. As the amount of liquid discharged at each stroke is known, the total volume that flows during a given period of time can be calculated by counting the number of cycles during that period. For that purpose, a special counter is available which screws into a tapped connection on the top cover of the pump. This counter records the number of pumping strokes, thus enabling the pump to function as a reliable flow meter.

### MAIN

FEATURES: No electric requirements.

OPTIONS: Level gauge.  
Stroke counter.

USE: To lift hot condensate or other liquids.

### AVAILABLE MODELS:

POPS – carbon steel.  
POPSS – stainless steel.  
(Carbon steel version is sandblasted, metalized and black painted).

SIZES: DN 25 x 25, DN 40 x 40, DN 50 x 50 and DN 80 x 50.

CONNECTIONS: Flanged EN 1092-1 PN 16.  
Female threaded ISO 7 Rp (threaded flanges).  
Others on request.

INSTALLATION: Horizontal installation.  
See IMI – Installation and maintenance instructions.

MOTIVE GAS: Steam, compressed air or other gases.

LIMITING CONDITIONS	
Minimum density	0,80 kg/L
Maximum viscosity	5 °Engler
Maximum motive pressure	10 bar
Minimum motive pressure	0,5 bar
Pump discharge per cycle – DN 25 to 50	16 L
Pump discharge per cycle – DN 80 x 50	25 L

BODY LIMITING CONDITIONS *					
	POPS			POPSS	
	ALLOW. PRESS.	RELAT. TEMP.		ALLOW. PRESS.	RELAT. TEMP.
PN 16	16 bar	50 °C	PN 16	16 bar	50 °C
	14 bar	100 °C		15 bar	100 °C
	13 bar	195 °C		12,7 bar	200 °C
	12 bar	250 °C		12 bar	250 °C
CLASS 150	16 bar	50 °C	CLASS 150	15,3 bar	50 °C
	14 bar	100 °C		13,3 bar	100 °C
	13 bar	195 °C		11,1 bar	200 °C
	12 bar	250 °C		10,2 bar	250 °C

Min. operating temp.: -10 °C; Design code: ASME VII.

\* Rating according to EN 1092-1:2018.

CE MARKING – GROUP 2 (PED – European Directive)	
PN 16	Category
All sizes	2 (CE marked)

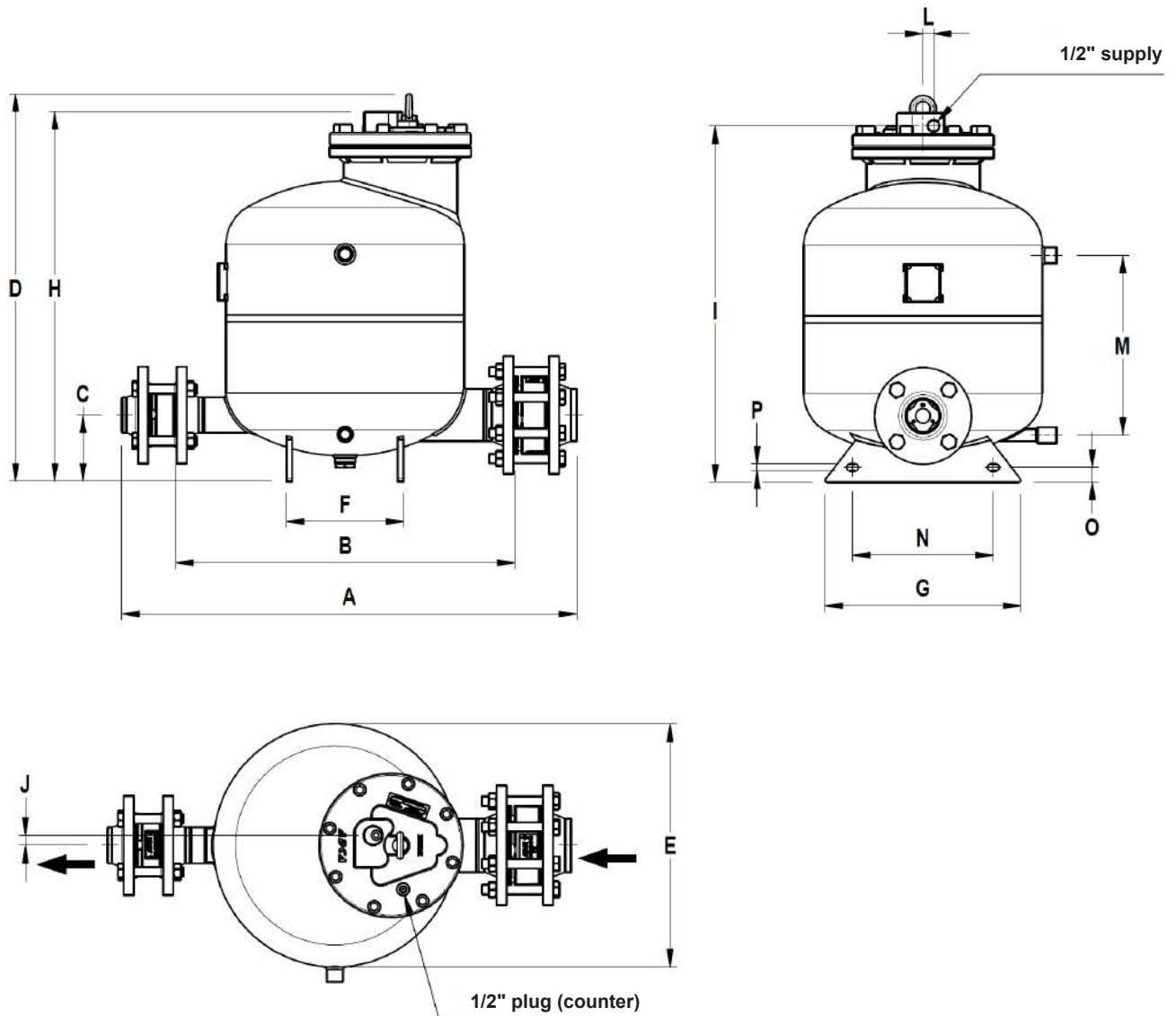

DIMENSIONS (mm)																	
SIZE	A *	B	C	D	E	F	G	H	I	J	L	M	N	O	P	WGT. (kg)	VOL. (L)
DN 25 x 25	578	444	100	640	323	160	244	617	598	17	18	327	150	25	12	71	31,7
DN 40 x 40	615	454	100	640	323	160	244	617	598	17	18	327	150	25	12	72,8	31,8
DN 50 x 50	644	460	100	640	323	160	244	617	598	17	18	327	150	25	12	74,5	31,9
DN 80 x 50	776	580	113	650	406	200	334	627	608	17	18	307	240	25	12	78,5	48,9

\* A – with welding neck EN 1092-1 flanges. Dimensions are different if threaded flanges are requested.

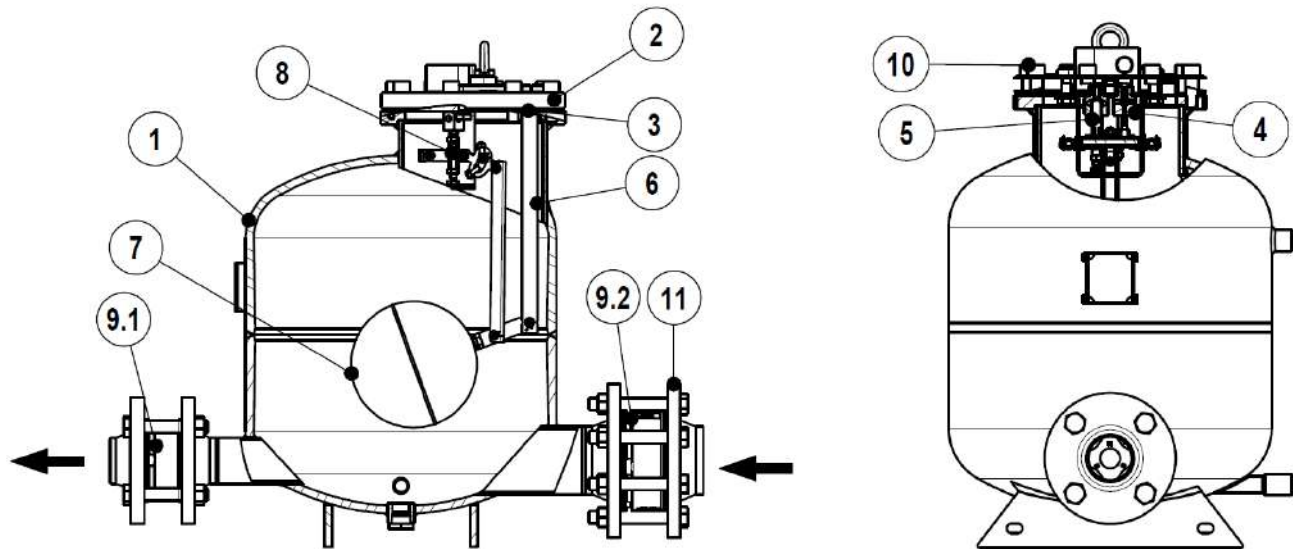

MATERIALS			
POS. N°	DESIGNATION	POPS	POPSS
1	Body	P265GH / 1.0425 ; P235GH / 1.0345 ; S235JR / 1.0038	AISI 316 / 1.4401; AISI 304 / 1.4301
2	Cover	GJS-400-15 / 0.7040; A216 WCB / 1.0619	A351 CF8M / 1.4408
3	* Cover gasket	Non asbestos	Non asbestos
4	* Inlet valve / Seat assembly	Stainless steel	Stainless steel
5	* Exhaust valve / Seat assembly	Stainless steel	Stainless steel
6	Internal mechanism	Stainless steel	Stainless steel
7	* Float	Stainless steel	Stainless steel
8	* Spring assembly (2 pieces)	Inconel	Inconel
9.1	* RD40 outlet check valve	A351 CF8M / 1.4408	A351 CF8M / 1.4408
9.2	* RD40 Inlet check valve	A351 CF8M / 1.4408	A351 CF8M / 1.4408
10	Bolts	Steel 8.8	Stainless steel A2-70
11	** PN 16 EN 1092-1 flanges	P250GH / 1.0460	AISI 316 / 1.4401

\* Available spare parts.

\*\* Welding neck EN 1092-1:2018 flanges. Threaded flanges on request.

### STROKE COUNTER

Available on request, it can be screwed directly into the top cover of the pump or above the pump, through a 1/2" size pipe for easier reading (max. 1 m).

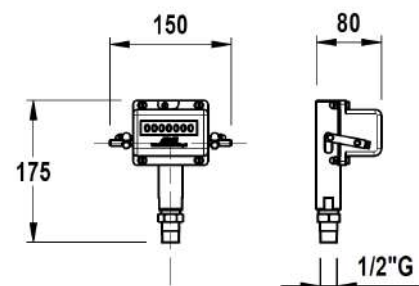

## SIZING AND INSTALLATION

### SIZING OF THE SYSTEM

The discharge capacity of the pump is a function of:

1. Condensate load (kg/h).
2. The pressure of the operating medium (steam, compressed air or other gases).
3. The total lift or back pressure the pump will have to overcome. This includes the change in fluid level elevation after the pump (0.0981 bar/m of lift), plus pressure in the return piping, plus the pressure drop in bar caused by pipe friction, plus any other system component pressure drop the pump exhaust will have to overcome (barg).
4. Filling head available (300 mm is recommended).

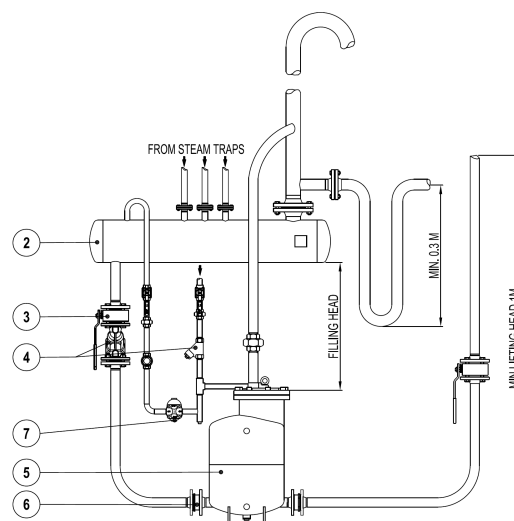

Fig.1

### INSTALLATION

Fig.1 shows a typical installation example of an ADCAMat POP. For further details and instructions, please contact manufacturer.

MATERIALS			
POS.	DESIGNATION	POS.	DESIGNATION
2	Receiver	5	POPS pump
3	Ball valve	6	RD40 disc check valve
4	Strainer	7	Steam trap

Table 1

### RECEIVER

A receiver is recommended to temporarily hold the liquid and prevent any flooding of the equipment, while the pump is performing a pumping cycle. A length of pipe of large diameter can be used.

SUGGESTED RECEIVER				
PUMP SIZE	25	40	50	80 x 50
Pipe size with 1 m lenght	6"	6"	8"	10"

Table 2

CAPACITY CORRECTION FACTOR FOR GASES OTHER THAN STEAM					
% Backpress. vs Motive press. (BP/MP)	10%	30%	50%	70%	90%
Correction factor	1,04	1,08	1,12	1,18	1,28

Table 3

CAPACITY MULTIPLYING FACTORS FOR OTHER FILLING HEADS				
PUMP SIZE	FILLING HEAD (mm)			
	150	300	600	900
DN 25 x 25	0,7	1	1,2	1,35
DN 40 x 40	0,7	1	1,2	1,35
DN 50 x 50	0,7	1	1,2	1,35
DN 80 x 50	0,9	1	1,08	1,2

Table 4

FLOW RATE (kg/h) INSTALLATION WITH 300 mm FILLING HEAD ABOVE THE PUMP COVER					
MOTIVE PRESSURE (bar)	TOTAL LIFT (bar)	DN 25 x 25	DN 40 x 40	DN 50 x 50	DN 80 x 50
1	0,35	840	1490	2320	4480
2		1030	1520	3160	5240
3		1140	1640	3560	5640
4		1180	1680	3840	5840
5		1240	1740	3910	5900
6		1270	1760	3940	5980
8		1300	2200	3990	6030
10		1310	2205	4000	6080
2	1	805	1560	2550	4080
3		940	1790	2990	4720
4		1080	1930	3160	5080
5		1110	2010	3200	5280
6		1140	2090	3250	5400
8		1180	2190	3280	5490
10		1190	2200	3320	5560
3		2	780	1495	2470
4	900		1690	2620	3950
5	1000		1820	2830	4230
6	1040		1910	2860	4740
8	1100		2010	2880	4880
10	1110		2060	2900	4960
4	3	740	1400	2360	3480
5		860	1545	2540	3640
6		910	1675	2560	3720
8		970	1805	2590	4050
10		980	1850	2650	4110
5	4	720	1335	2280	2690
6		820	1480	2460	2860
8		910	1675	2500	3190
10		930	1760	2540	3380
6	5	680	1290	2080	2520
8		740	1530	2180	2740
10		810	1630	2220	2860
7	6	660	1230	1880	1940
8		730	1370	1940	2240
10		820	1490	2150	2360

Table 5 (based on liquid specific gravity 0,9 – 1,0).

**Example:**

Condensate load 1800 kg/h  
 Filling head 150 mm  
 Motive fluid Compressed air  
 Available pressure 8 bar  
 Vertical lift after pump 6 m  
 Return piping pressure 1,5 bar  
 Piping friction pressure drop Negligible

**Calculations:**

Total back pressure:  $1,5 \text{ bar} + (6 \text{ m} \times 0,0981) = 2,09 \text{ bar}$ .  
 Pump choice, assuming steam as motive fluid, at a pressure of 8 bar and a back pressure of 3 bar: the DN 50 pump has a capacity of 2590 kg/h, according to Table 5, so it is the one we should select.

**Correction for filling Head:**

With 150 mm filling head the correction factor from Table 4 is 0,7. The corrected capacity is:  
 $2590 \text{ kg/h} \times 0,7 = 1813 \text{ kg/h}$ .

**Correction for air as a motive fluid:**

The % back pressure  $2,09 \text{ bar} / 8 \text{ bar} = 30\%$   
 The correction factor from table 3, is 1,08.  
 The corrected capacity is  $1813 \text{ kg/h} \times 1,08 = 1958 \text{ kg/h}$ ,  
 and so, the DN 50 pump is still recommended.

## TYPICAL APPLICATIONS

### Condensate recovery – open system

The pump removes high temperature condensate without cavitation problems.

WARNING: Vent line must be unrestricted and self draining to the receiver.

MATERIALS			
POS.	DESIGNATION	POS.	DESIGNATION
1	Heat exchanger	5	POPS pump
2	Receiver	6	RD40 disc check valve
3	Ball valve	7	Steam trap
4	Strainer	8	Air vent

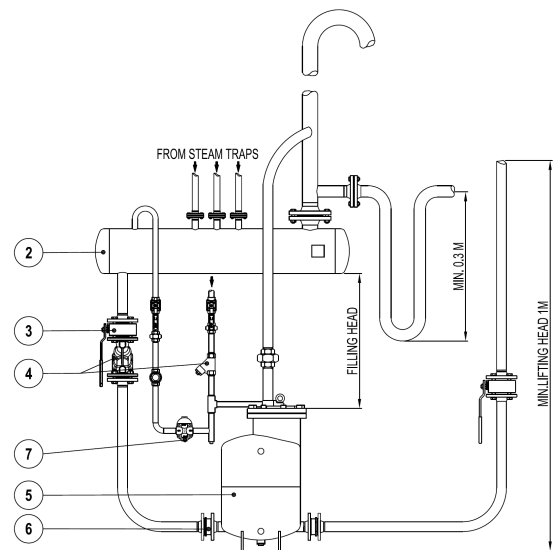

### Removal of condensate under pressure with POPS pump and steam trap combination

When the steam pressure is sufficient to overcome back pressure, the trap operates.

If the pressure decreases, then the pressure operated pump starts to work, removing the condensate by pumping through the float steam trap.

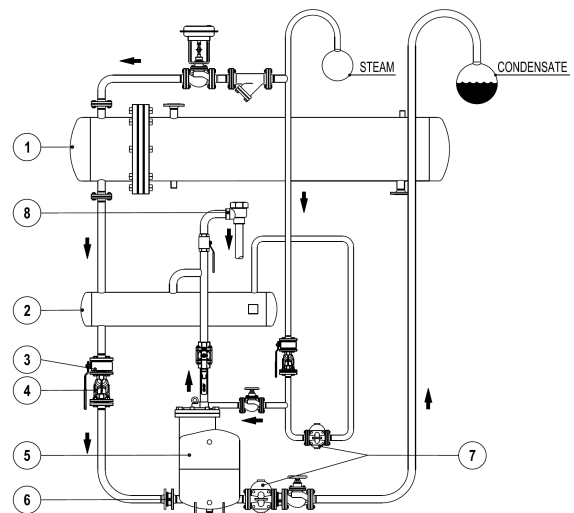

### Drainage of a single unit under vacuum (max. 0,2 bar abs)

Head H1 must range between 1 and 2 m. The lift H must be as minimum as possible, but never less than 1 m (otherwise a siphon is required, as shown in H2).

Use steam as operating medium (max. pressure 2 – 3 bar).

