

ADCAMAT PACKAGED AUTOMATIC PUMP (Suitable for steam supply) POPS-KT (Triplex)

DESCRIPTION

The POPS-K packaged pump units can be used to lift or displace hot condensate and other liquids even in hazardous areas.

A POPS-KT (Triplex) packaged unit is comprised by three Adcamat pumps in parallel, a vented receiver and all auxiliary items, compactly mounted on a metal frame, piped and ready for connection.

Packaged units save time, work and site costs. In addition, they ensure that the installation of the pump is correct in every detail.

Two or more units can be connected in parallel to cope with flow rates beyond the capacity of a single pump.

Packaged units for operation with compressed air are also available.

All connections are flanged EN 1092-1 PN 16.

Threaded flanges and/or other connection standards available on request.

For operating conditions and pumping capacities, please refer to the information sheet IS 9.101 E.

How to order: i.e. ADCAMAT POPS-KD carbon steel packaged pump, steam operated, flanged PN 16 DN 80 x 50.



CE MARKING – GROUP 2 (PED – European Directive)

PN 16	Category
All sizes	2 (CE marked)

MATERIALS	
POS. N°	DESIGNATION
1	POPS pumps
2	Receiver
3	MWS1 wafer ball valve
4	IS16F strainer
5	RD40 disc check valve
6	M3i ball valves
7	Overflow
8	IS140 Y strainer
9	UCX41 + UBS20 steam trap
10	Metal frame

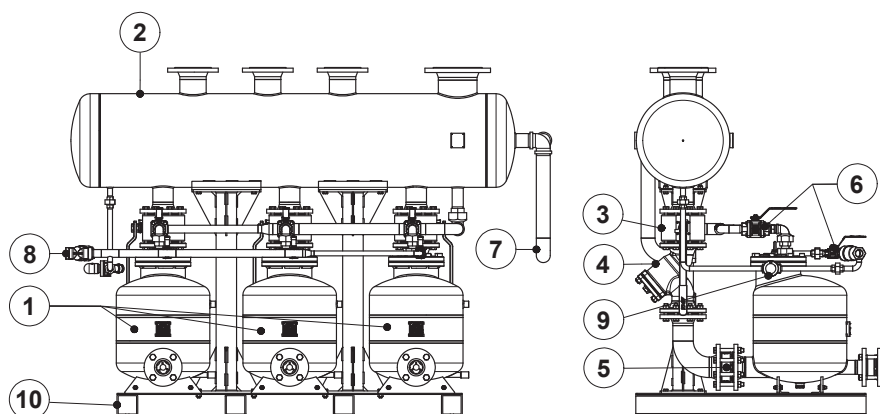

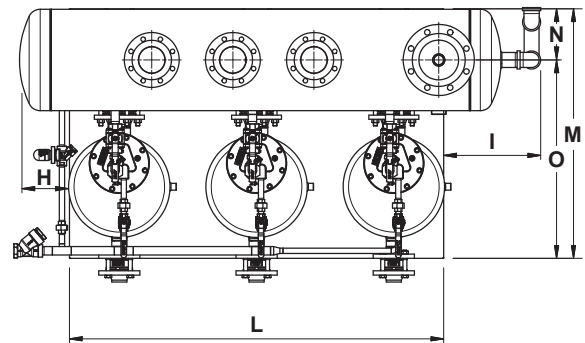
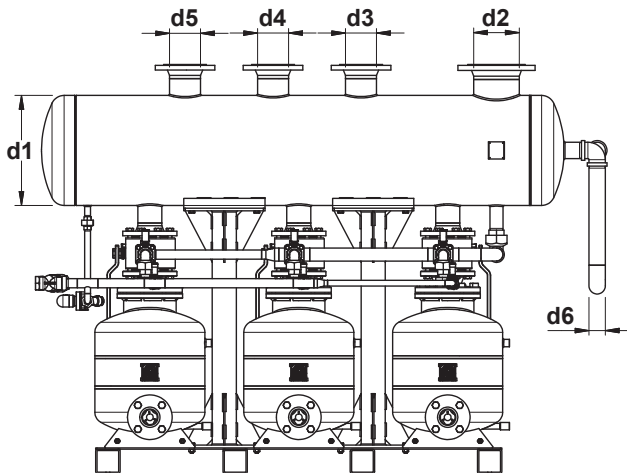
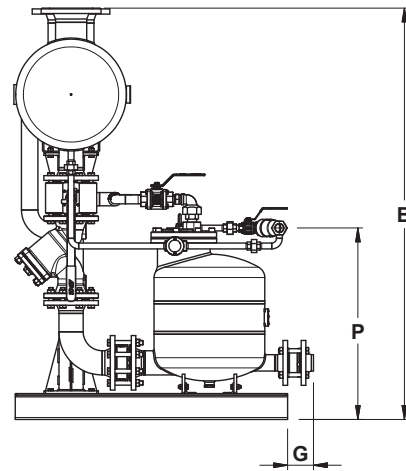
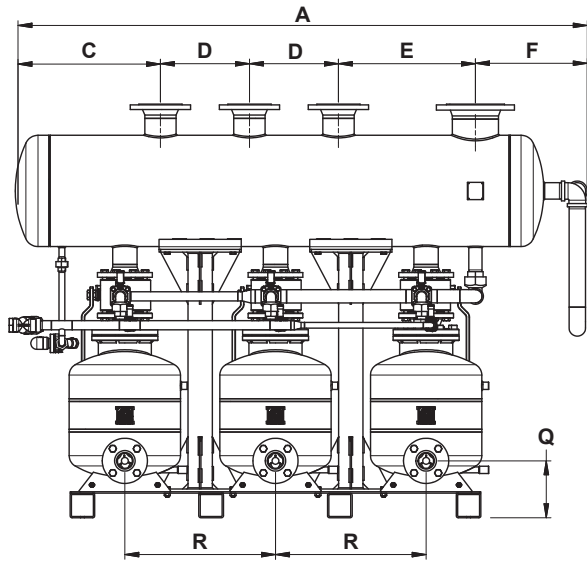

CONNECTIONS SIZE

SIZE	d1 (mm)	d2	d3	d4	d5	d6
3 x DN 50x50	406	DN 150	DN 80	DN 80	DN 80	2"
3 x DN 80x50	406	DN 150	DN 100	DN 100	DN 100	2"

LIMITING CONDITIONS

Receiver – Max. operating pressure	0,5 bar
Pump	See IS 9.101

d2 – vent; d3, d4 and d5 – condensate inlets; d6 – overflow.

DIMENSIONS (mm)

SIZE	A	B	C	D	E	F	G	H	I	J	L	M	N	O	P	Q	R
3 x DN 50x50	2088	1497	530	325	500	408	–	200	388	1500	1000	205	795	693	195	550	550
3 x DN 80x50	2088	1509	530	325	500	408	95	200	388	1500	1000	205	795	709	208	550	550

Dimensions subject to change without notice. Consult manufacturer for certified dimensions and weight.