

AUTOMATIC PUMP TRAP PPT14

DESCRIPTION

The ADCAMat PPT14 automatic pump trap is specially recommended where stall condition may occur due to poor steam trap condensate discharge capacity, caused by temporary insufficient pressure drop.

The equipment combines the features of a float steam trap and a pressure operated pump, in one single unit.

Whenever the steam trap function is incapable of draining condensate, the pump function is activated (using external steam pressure). The pump replaces the necessary positive pressure to lift the condensate to the return system, before water logging occurs, avoiding water hammer and consequent noise, equipment damage, corrosion, unstable temperature control, etc.

MAIN FEATURES

- Compact design.
- No electric requirements.
- No NPSH issues.
- Operation under vacuum conditions.
- No motive or flash steam is lost.
- Low filling head for minimal installation space requirements.

- OPTIONS:** Level gauge.
- USE:** Drain and lift condensate from heat exchangers (among others).
- AVAILABLE MODELS:** PPT14S – carbon steel.
 PPT14SS – stainless steel.
- SIZES:** 1 1/2" x 1" and 2" x 1 1/2".
 DN 40 x 25 and DN 50 x 40.
- CONNECTIONS:** Flanged EN 1092-1 PN 16.
 Flanged ASME B16.5 Class 150.
 Female threaded ISO 7 Rp (threaded flanges).
 Others on request.
- INSTALLATION:** Horizontal installation in a closed loop system.
 See IMI – Installation and maintenance instructions.
- MOTIVE GAS:** Steam.



CE MARKING – GROUP 2 (PED – European Directive)	
PN 16	Category
All sizes	2 (CE marked)

OPERATING LIMITING CONDITIONS

Minimum density	0,80 kg/L
Maximum motive pressure	10 bar
Minimum motive pressure	1 bar
Pump discharge per cycle (approx.)	11 L

Remark: It is recommended that the motive pressure does not exceed 1 to 4 bar above the expected back pressure applied to the pump.

**FLOW RATE CAPACITY (kg/h)
OPERATING IN PUMP MODE W/ 300 mm FILLING HEAD**

MOTIVE PRESSURE (bar)	TOTAL LIFT (bar)	1 1/2" x 1" DN 40 x 25	2" x 1 1/2" DN 50 x 40	
1	0,35	1050	1220	
2		1190	1490	
3		1220	1530	
4		1280	1600	
6		1310	1640	
8		1380	1730	
10		1460	1830	
2	1	940	1180	
3		1020	1280	
4		1110	1390	
6		1200	1510	
8		1290	1620	
10		1380	1730	
3	2	720	900	
4		850	1070	
5		940	1180	
6		1010	1260	
8		1130	1410	
10		1200	1490	
4	3	620	780	
5		730	920	
6		840	1050	
8		980	1230	
10		1090	1370	
5		4	540	680
6	690		870	
8	880		1100	
10	960		1190	
6	5		520	650
8			730	910
10		840	1060	
7		6	530	670
8			640	810
10			730	920

BODY LIMITING CONDITIONS *

PPT14S		PPT14SS		
FLANGED PN 16 / CLASS 150		FLANGED PN 16	FLANGED CLASS 150	RELATED TEMP.
ALLOWABLE PRESSURE	RELATED TEMP.	ALLOWABLE PRESSURE	ALLOWABLE PRESSURE	
16 bar	50 °C	16 bar	15,3 bar	50 °C
14 bar	100 °C	15 bar	13,3 bar	100 °C
13 bar	195 °C	12,7 bar	11,1 bar	200 °C
12 bar	250 °C	12 bar	10,2 bar	250 °C

Min. operating temp.: -10 °C; Design code: AD-Merkblatt.

* Rating according to EN 1092-1:2018.

RESERVOIR SIZING TABLE FOR EQUALIZED, CLOSED SYSTEM INSTALLATION

FLOW RATE (kg/h)	RESERVOIR SIZE (DN)						
	40	50	80	100	150	200	250
	RESERVOIR LENGTH (mm)						
≤ 300	1200	700	-	-	-	-	-
400	1500	1000	-	-	-	-	-
500	2000	1200	500	-	-	-	-
600	-	1500	600	-	-	-	-
800	-	2000	800	500	-	-	-
1000	-	-	1000	700	-	-	-
1500	-	-	1500	1000	-	-	-
2000	-	-	2000	1300	600	-	-
3000	-	-	-	2000	900	500	-
4000	-	-	-	-	1200	700	-
5000	-	-	-	-	1400	800	500
6000	-	-	-	-	1700	1000	600
7000	-	-	-	-	2000	1200	700
8000	-	-	-	-	-	1300	800
9000	-	-	-	-	-	1500	900
10000	-	-	-	-	-	1700	1000

Remark: Reservoir length can be reduced by 50% when the motive pressure divided by the back pressure is ≥ 2.

CAPACITY MULTIPLYING FACTORS FOR OTHER FILLING HEADS

PUMP SIZE	FILLING HEAD "H" (mm)			
	150	300	600	900
All sizes	0,7	1	1,2	1,35

Remark: Filling head "H" is shown in Fig. 1.

FLOW RATE CAPACITY (kg/h) OPERATING IN STEAM TRAP MODE

MODEL	SIZE	DIFFERENTIAL PRESSURE (bar)											
		0,1	0,3	0,5	0,7	1	1,5	2	3	4	5	7	10
PPT14	1 1/2" x 1" – DN 40 x 25	650	1100	1500	1700	2000	2600	3000	3510	3990	4400	5400	6200
PPT14	2" x 1 1/2" – DN 50 x 40	1050	1750	2400	2700	3400	3900	4500	5900	6600	7650	8500	10100

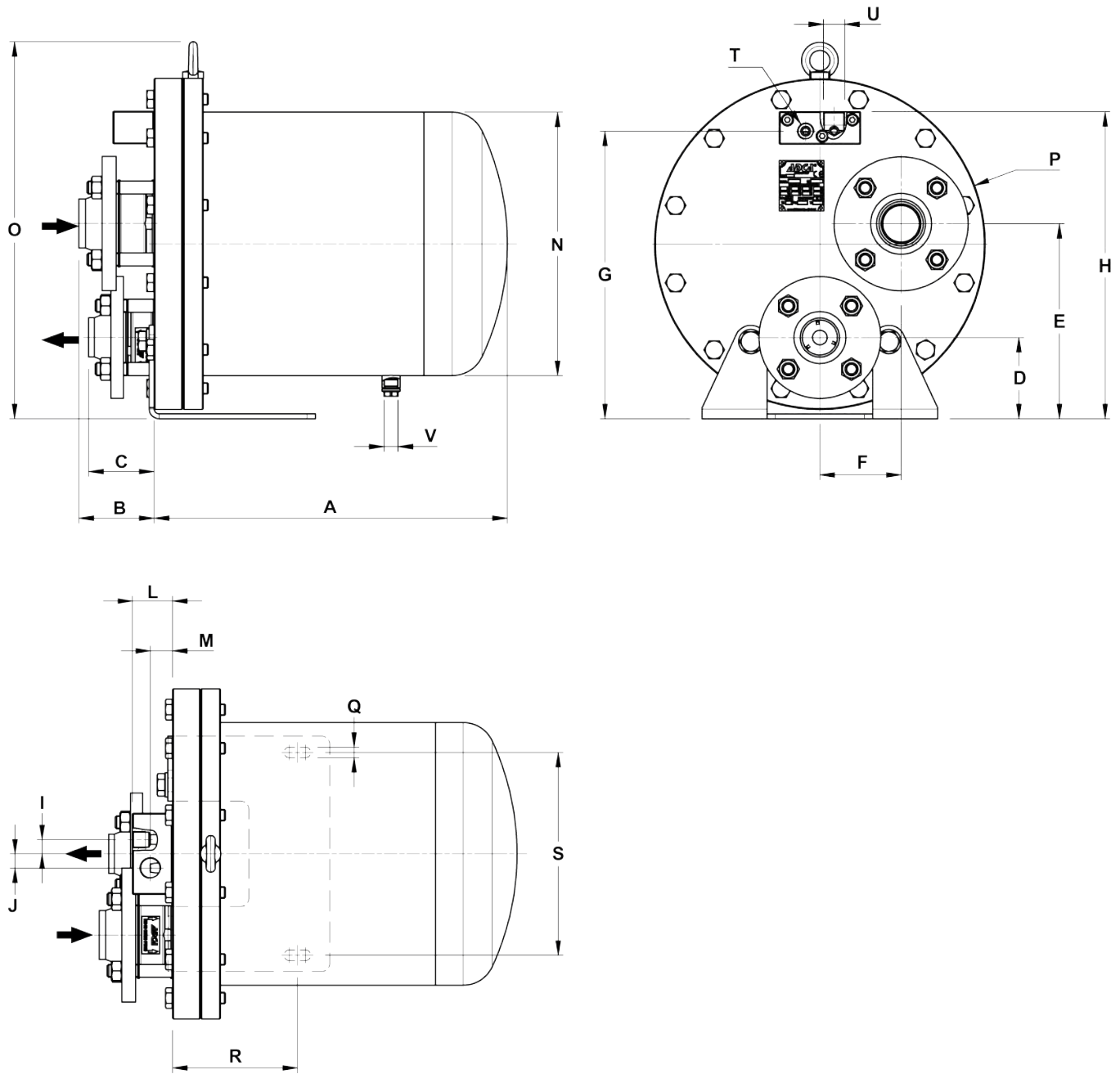

DIMENSIONS (mm) – PN 16

SIZE	A	B*	C*	D	E	F	G	H	I	J	L	M	N	O	ØP	Q	R	S	T**	U**	V**	WGT. (kg)	VOL. (L)
DN 40 x 25	425	80	64	100	240	100	354	378	17,5	17,5	50	28	324	464	407	13	154	250	1/2"	3/4"	3/8"	81,2	25
DN 50 x 40	425	91	79	100	240	100	354	378	17,5	17,5	50	28	324	464	407	13	154	250	1/2"	3/4"	3/8"	84	25

DIMENSIONS (mm) – CLASS 150

SIZE	A	B*	C*	D	E	F	G	H	I	J	L	M	N	O	ØP	Q	R	S	T**	U**	V**	WGT. (kg)	VOL. (L)
1 1/2" x 1"	425	97	80	100	240	100	354	378	17,5	17,5	50	28	324	464	407	13	154	250	1/2"	3/4"	3/8"	80,6	25
2" x 1 1/2"	425	106	96	100	240	100	354	378	17,5	17,5	50	28	324	464	407	13	154	250	1/2"	3/4"	3/8"	83,3	25

* Dimensions are different if threaded flanges are requested;

** As standard, in versions manufactured with EN 1092-1 PN 16 flanges, these connections are female threaded ISO 7 Rp. In versions with ASME B16.5 flanges, these connections are female threaded NPT.

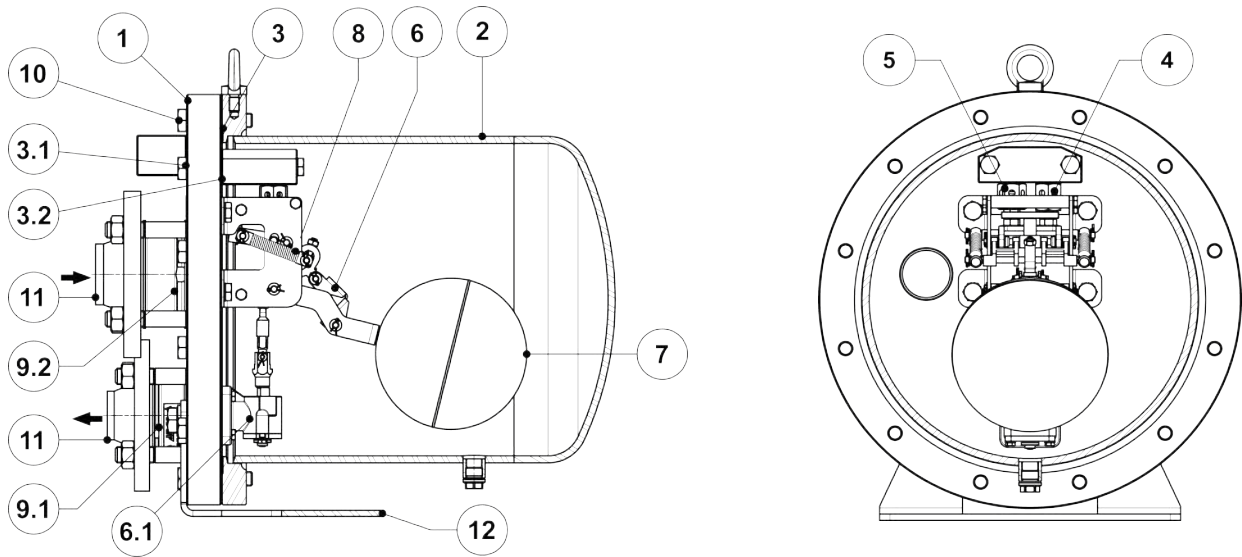

MATERIALS			
POS. N°	DESIGNATION	PPT14S	PPT14SS
1	Body	S355JR / 1.0045	AISI 316 / 1.4401; AISI 316L / 1.4404
2	Cover	S355JR / 1.0045; P265GH / 1.0425; P235GH / 1.0345	AISI 304 / 1.4301; AISI 316 / 1.4401
3	* Cover gasket	Stainless steel / Graphite	Stainless steel / Graphite
3.1	* Gasket	Stainless steel / Graphite	Stainless steel / Graphite
3.2	* Gasket	Stainless steel / Graphite	Stainless steel / Graphite
4	* Inlet valve / Seat assembly	Stainless steel	Stainless steel
5	* Exhaust valve / Seat assembly	Stainless steel	Stainless steel
6	Snap-action pump mechanism	Stainless steel	Stainless steel
6.1	Steam trap unit	Stainless steel	Stainless steel
7	* Float	Stainless steel	Stainless steel
8	* Spring assembly (2 pieces)	Inconel	Inconel
9.1	* RD40 outlet check valve	A351 CF8M / 1.4408	A351 CF8M / 1.4408
9.2	* RD40 Inlet check valve	A351 CF8M / 1.4408	A351 CF8M / 1.4408
10	Bolts	Steel 8.8	Stainless steel A2-70
11	** PN 16 EN 1092-1 flanges	P250GH / 1.0460	AISI 316 / 1.4401
12	Pump support	S235JR / 1.0038	AISI 304 / 1.4301

* Available spare parts.

** Welding neck EN 1092-1:2018 flanges.

SIZING AND INSTALLATION

SIZING

To accurately size a pump trap, the following information must be provided:

1. Heat exchanger (or process equipment) maximum steam or condensate load, in kg/h.
2. Heat exchanger (or process equipment) operating pressure at full load in bar g or, alternatively, the heat exchanger maximum operating pressure in bar g and the over design percentage.
3. Motive steam pressure available to operate the pump trap, in bar g.
4. The total lift or back pressure the pump will have to overcome. This includes the change in the fluid level elevation after the pump (0,0981 bar/m of lift), plus pressure in the returning pipe, plus the pressure drop caused by pipe friction, plus any other system component pressure drop the pump will have to overcome, in bar g.
5. Maximum controlled temperature of the medium to be heated (secondary fluid outlet temperature), in °C.
6. Minimum temperature of the medium to be heated (secondary fluid minimum inlet temperature), in °C.
7. Installation head available “H” (see Fig. 1) in mm or any other dimension that allows its determination.

- H – Filling head
- S – Process steam supply
- S1 – Motive steam
- C – Condensate return
- V – Automatic air venting
- CW – Cold water inlet
- HW – Hot water outlet

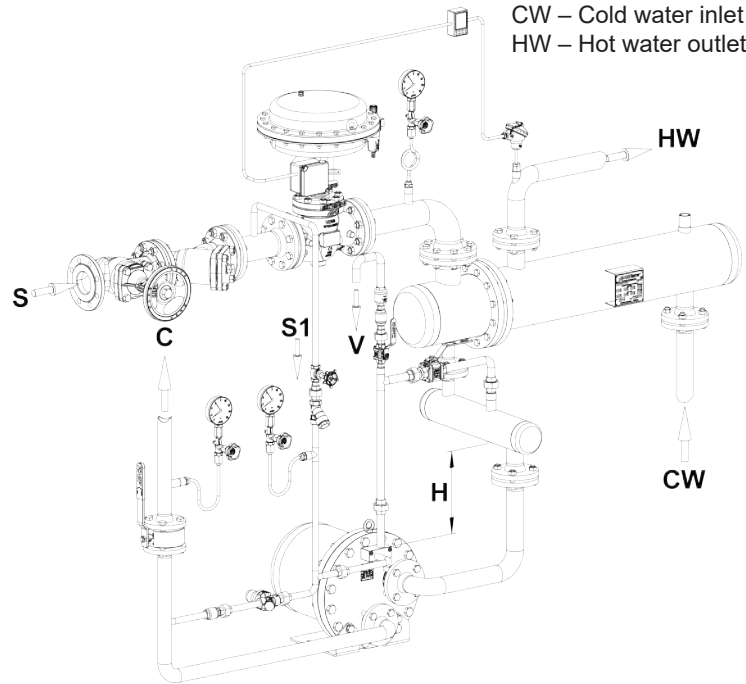

Fig.1

For information on how to predict stall refer to IS 9.085 Technical Information Sheet - Understanding stall condition - or consult the manufacturer.

RESERVOIR

A reservoir is recommended to temporarily hold the liquid and prevent any flooding of the equipment, while the pump is performing a pumping cycle. A length of pipe of large diameter can be used (see reservoir sizing table).

NOTE: All ADCAMat automatic pump traps feature two mechanisms, combining the characteristics of a float steam trap and a pressure operated pump. When certain that the system backpressure is always superior to the equipment upstream pressure then an ADCAMat pressure operated pump (without steam trap) is the ideal solution as long as it is installed in a closed loop.

In extreme cases, where the system condensate load is above the discharge capacity of all ADCAMat automatic pump trap models, it is recommended to install an ADCAMat pressure operated pump in combination with a high capacity FLT series steam trap. In these scenarios, please consult manufacturer.

OPERATION

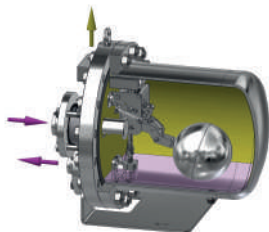

1. In the first instance, the steam intake valve is closed, while the vent valve is open. As condensate flows into the body through the inlet check valve, the PPT14 can operate in a closed loop application, in one of two ways (as a steam trap or pressure operated pump).

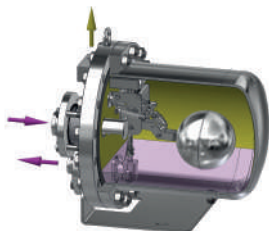

2. If the inlet pressure is greater than the back pressure, the PPT14 works as a steam trap, continuously discharging condensate by differential pressure. At this point the steam intake valve remains closed and the vent valve open.

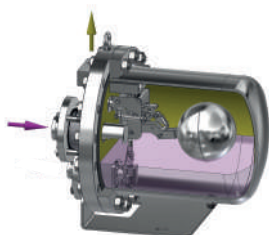

3. As soon as, e.g., the equipment's control valve starts to modulate, the steam pressure will decrease. The lower differential pressure decreases the PPT14's ability to discharge as a steam trap causing the condensate level to rise inside the body. Vacuum may even occur at this stage.

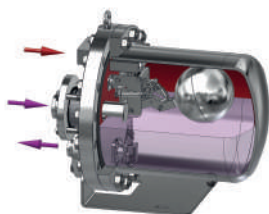

4. If this situation would persist, the condensate would eventually flood the equipment, causing problems. However, by using a PPT14, as the float reaches its highest position, the snap action mechanism actuates, closing the vent valve and opening the steam intake valve. Steam will then replace the necessary positive pressure to pump out the condensate. At this point the PPT14 works as a pressure operated pump.

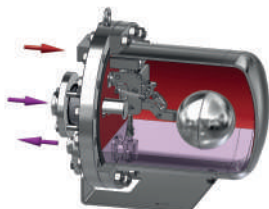

5. The float starts to fall as the condensate level inside the body drops and is discharged to the return system. When the float reaches its lowest position, the snap action mechanism resets.

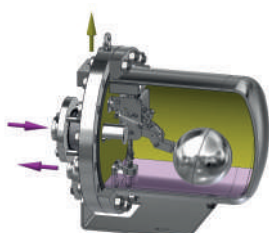

6. As the motive steam valve closes and the vent valve opens, equalizing the body pressure with the upstream pressure, the condensate is allowed to flow once again into the PPT14. The cycle then repeats itself and, with enough differential pressure, the PPT14 resumes as a steam trap or, otherwise, as a pump.