

HUMIDITY SEPARATORS SH25 PN 16 and PN 40

DESCRIPTION

The SH25 series horizontal centrifugal separators remove moisture from steam and compressed air systems. Steam or compressed air pass through the separator and, as a result of centrifugal forces, impact and swirling effects, the particles with a heavier specific gravity, such as water and oil droplets, moisture in suspension, dirt and scale are separated from the fluid.

The condensate collected at the bottom of the separator must be automatically drained by a suitable steam or compressed air trap.

MAIN FEATURES

- Inline design.
- No moving parts.
- Maintenance-free design.

- OPTIONS:** Flanged drain connection.
- USE:** Steam, compressed air and other gases.

AVAILABLE MODELS: SH25/S – carbon steel.

SIZES: 1/2" to 6"; DN 15 to DN 150.

CONNECTIONS: Flanged EN 1092-1 PN 16 or PN 40.
Flanged ASME B16.5 Class 150 or 300.

INSTALLATION: Horizontal with the condensate discharge pointing downwards.
See IMI – Installation and maintenance instructions.



CE MARKING – GROUP 2 (PED – European Directive)

PN 16	Category	PN 40	Category
1/2" to 1" – DN 15 to 25	SEP	1/2" to 1 1/4" – DN 15 to 32	1 (CE marked)
1 1/4" to 2" – DN 32 to 50	1 (CE marked)	1 1/2" to 3" – DN 40 to 80	2 (CE marked)
2 1/2" to 6" – DN 65 to 150	2 (CE marked)	4" to 6" – DN 100 to 150	3 (CE marked)

BODY LIMITING CONDITIONS *

FLANGED PN 16		FLANGED CLASS 150		FLANGED PN 40 / CLASS 300	
ALLOWABLE PRESSURE	RELATED TEMPERATURE	ALLOWABLE PRESSURE	RELATED TEMPERATURE	ALLOWABLE PRESSURE	RELATED TEMPERATURE
16 bar	50 °C	16 bar	50 °C	40 bar	50 °C
14 bar	100 °C	14 bar	100 °C	37 bar	100 °C
13 bar **	195 °C	13 bar **	195 °C	31 bar **	239 °C
12 bar	250 °C	–	–	27 bar	300 °C

* According to EN 1092-1:2018; ** PMO – Maximum operating pressure for saturated steam.

Body limiting conditions PN 40 or below, depending on the type of connection adopted. Rating PN 40 for threaded and SW versions.
Minimum operating temperature: -10 °C. Design code: AD-Merkblatt.

MATERIALS	
DESIGNATION	MATERIAL
Body	P235GH / 1.0325
Heads	P265GH / 1.0425
Inlet / outlet pipes	P235GH / 1.0325
EN flanges	P250GH / 1.0460
ASME flanges	ASTM A105 / 1.0432
Sockets	ASTM A105 / 1.0432
Internals	S235JR / 1.0038

FLANGE CONNECTIONS			
RATING	SIZE	EN STANDARD	ASME STANDARD
PN 16	* DN 15 to 50	EN 1092-1 PN 40	ASME B16.5 Class 150
PN 16	DN 65 to 100	EN 1092-1 PN 16	ASME B16.5 Class 150
PN 40	DN 15 to 100	EN 1092-1 PN 40	ASME B16.5 Class 300

* Flanges EN 1092-1 PN 16 and PN 40, from DN 15 to DN 50, have the same number and size of holes.

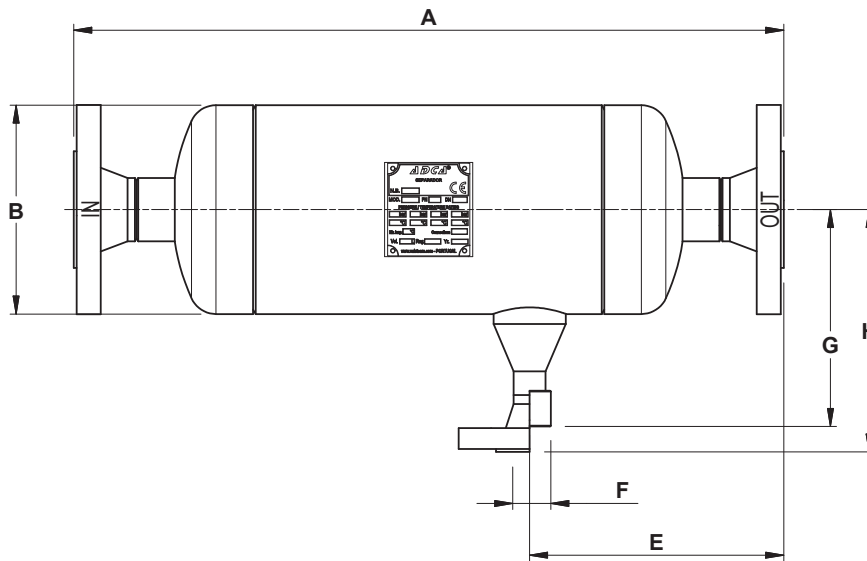

DIMENSIONS (mm)																
SIZE	A PN 16	A PN 40	A CLASS 150	A CLASS 300	B	E PN 16	E PN 40	E CLASS 150	E CLASS 300	F *	G	H PN 16 / PN 40	H CLASS 150	H CLASS 300	VOL. (L.)	WGT. (kg)
1/2" – DN 15	431	431	450	460	114	166	171	176	185	1/2"	134	148	158	162	2.5	5.7
3/4" – DN 20	435	435	460	470	114	168	173	180	190	1/2"	134	148	158	162	2.6	6.4
1" – DN 25	435	435	465	479	114	168	173	183	195	1/2"	134	148	158	162	2.6	6.9
1 1/4" – DN 32	475	475	505	521	140	180	186	195	209	3/4"	168	182	194	199	4.6	10.8
1 1/2" – DN 40	515	515	549	562	140	183	189	200	212	3/4"	168	182	194	199	5.2	11.8
2" – DN 50	550	550	581	593	168	193	210	208	232	3/4"	182	196	208	213	7.8	16.0
2 1/2" – DN 65	555	570	605	618	168	195	220	220	244	3/4"	182	196	208	213	8.1	16.8
3" – DN 80	625	640	665	682	219	245	258	264	280	1"	212	222	237	243	15.1	27.6
4" – DN 100	750	776	798	818	273	273	306	297	326	1"	239	249	264	270	29.1	40.9
5" – DN 125	860	886	928	947	324	289	324	322	355	1"	264	274	289	296	48.2	62.4
6" – DN 150	910	950	978	997	356	298	321	332	344	1"	280	290	305	312	62.5	80.4

* As standard, in versions with EN flanges and female ISO 7 Rp threads, these connections are female threaded ISO 7 Rp. In versions with ASME flanges, female NPT threads or SW, these connections are female threaded NPT.