

**TUBULAR HEATING COILS
R SERIES
(STEAM TO WATER)**

DESCRIPTION

The ADCA R series steam to water tubular heating coils are shorter and lighter than the alternative tubular heating coils manufactured with smooth pipes. The use of extruded low fin tube has the advantage that it can improve the external surface and thermal performance.

MAIN FEATURES

Corrosion-resistant low finned stainless steel tube bundle construction.
Straight tubes for easy cleaning.
Floating head at the end of the tube bundle, avoiding tube stresses caused by thermal expansion and contraction.

OPTIONS: Special designs.

USE: Steam, water, hot condensate and other fluids compatible with the construction.

AVAILABLE

MODELS: R5, R6, R8 and R10.

CONNECTIONS: Flanged EN 1092-1 PN 16.
Flanged ASME B16.5 Class 150.
Threaded on request.

INSTALLATION: Horizontally on vertical or horizontal vessels.
See IMI – Installation and maintenance instructions.



CE MARKING – GROUP 2 (PED – European Directive)	
PN 16	Category
R5.075 to R5.150	1 (CE marked)
R6.075 to R6.150	1 (CE marked)
R8.075 to R8.150	2 (CE marked)
R10.075 to R10.150	2 (CE marked)

BODY LIMITING CONDITIONS		
FLANGED PN 16 *	FLANGED CLASS 150 **	RELATED TEMP.
ALLOWABLE PRESSURE	ALLOWABLE PRESSURE	
16 bar	15,3 bar	50 °C
15 bar	13,3 bar	100 °C
12,7 bar ***	11,1 bar ***	200 °C
12 bar	–	250 °C

Min. operating temp.: -10 °C; Design code: AD-Merkblatt
* According to EN 1092-1:2018.
** According to EN 1759-1:2004.
*** PMO – Maximum operating pressure for saturated steam.

MATERIALS	
DESIGNATION	MATERIAL
Tube bundle	AISI 316L / 1.4404
Tube sheet	AISI 316 / 1.4401
Heads	S235JR / 1.0038; P235GH / 1.0305
Inlet / outlet pipes	P235GH / 1.0305
EN flanges	P250GH / 1.0460
ASME flanges	ASTM A105 / 1.0432
Sockets	ASTM A105 / 1.0432
Supports	S235JR / 1.0038

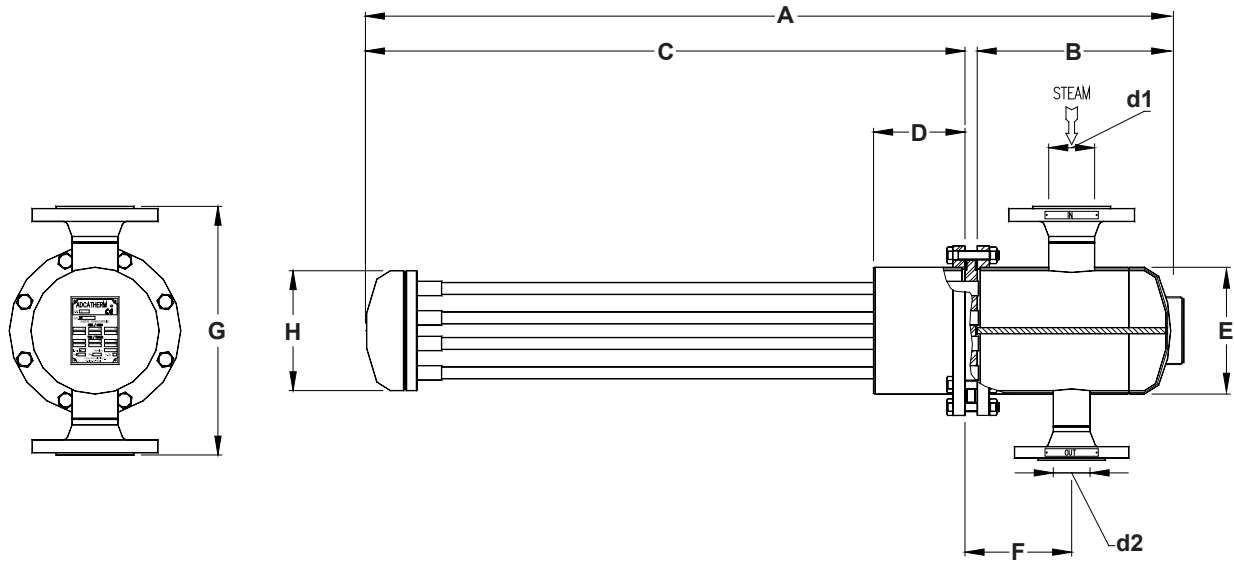

DIMENSIONS (mm)										
MODEL	A	B	C	D	E	F	G	H	d1 *	d2 *
R5.075	1010	234	762	120	139	145	340	128	40	25
R5.100	1260	234	1012	120	139	145	340	128	40	25
R5.150	1760	234	1512	120	139	145	340	128	40	25
R6.075	1040	254	770	120	168	145	368	157	65	40
R6.100	1290	254	1020	120	168	145	368	157	65	40
R6.150	1790	254	1520	120	168	145	368	157	65	40
R8.075	1060	264	780	130	220	145	420	204	80	50
R8.100	1310	264	1030	130	220	145	420	204	80	50
R8.150	1810	264	1530	130	220	145	420	204	80	50
R10.075	1097	304	775	130	273	145	473	257	80	50
R10.100	1347	304	1025	130	273	145	473	257	80	50
R10.150	1847	304	1525	130	273	145	473	257	80	50

* Merely indicative values. Sizes to be determined according to flow conditions.
 Since each coil is built to suit specific plant requirements, consult manufacturer for certified dimensions and weight.

TYPICAL INSTALLATION

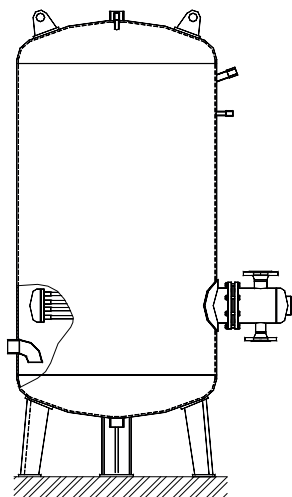

Vertical vessel

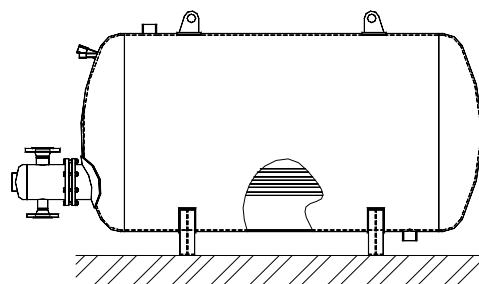

Horizontal vessel