

PISTON SENSING PRESSURE REDUCING VALVE PRV41

DESCRIPTION

The ADCA PRV41 series direct acting, spring-loaded piston sensing, balanced plug pressure reducing valves are designed for use on compressed air, water and other gases or liquids compatible with the materials of the construction.

They are suitable for pressure reducing stations at the point of use on different industrial applications.

MAIN FEATURES

Compact design.
Balanced plug.
Machined from bar stock materials.

OPTIONS: Different soft valves for water and gases.
Relieving – Internal relief valve to allow reduced outlet pressure in a no-flow condition.
1/4" outlet gauge connection on body.
Top cap (adjustment screw with cover).

USE: Compressed air, water and other gases and liquids compatible with the construction.

AVAILABLE MODELS: PRV41SS – stainless steel, piston sensing.

SIZES: 1/4" to 1/2"; DN 15.

CONNECTIONS: Female threaded ISO 7 Rp or NPT.
Flanged EN 1092-1 PN 40 to PN 320.
Flanged ASME B16.5 Class 150, 300 or 600.

INSTALLATION: Horizontal or vertical installation.
See IMI – Installation and maintenance instructions.
A "Y" strainer should be installed upstream of the valve.



FLOW RATE COEFFICIENTS (m ³ /h)			
SIZE	1/4"	3/8"	1/2" – DN 15
Kvs	0,7	0,8	0,9

LIMITING CONDITIONS	
Valve model	PRV41SS
Body design conditions	PN 320
Maximum upstream pressure	220 bar
Maximum downstream pressure	200 bar
Minimum downstream pressure	3 bar
Maximum design temperature *	80 °C
Maximum recommended reducing ratio	40:1

* Others on request.

CE MARKING – GROUP 2 (PED – European Directive)	
PN 320	Category
1/4" to 1/2" – DN 15	SEP

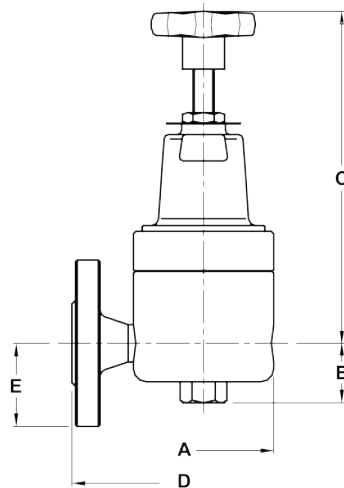

DIMENSIONS (mm)													
THREADED				PN 40			PN 63/100			PN 250/320			
SIZE	A	B	C	WEIGHT (kg)	D *	E	WEIGHT (kg)	D *	E	WEIGHT (kg)	D *	E	WEIGHT (kg)
1/4"	80	35	200	2,7	–	–	–	–	–	–	–	–	–
3/8"	80	35	200	2,7	–	–	–	–	–	–	–	–	–
1/2" – DN 15	80	35	200	2,7	150	47,5	4,1	210	52,5	5	230	65	7,3

* Different lenghts on request.

Remark: DN 15 PN 40 face to face dimmensions adopted as per DN 20.

MATERIALS		
POS. N°	DESIGNATION	MATERIAL
1	Valve body	AISI 316 / 1.4401
1A	Piston sleeve	AISI 316 / 1.4401
2	Top cover	AISI 316 / 1.4401
		A351 CF8M / 1.4408
3	Seat cover	AISI 316 / 1.4401
4	* O-ring	NBR
5	* Piston valve	AISI 316 / 1.4401
6	* Valve head	NBR ; EPDM ; PTFE; etc.
6A	Pushrod	AISI 304 / 1.4301
6B	* Valve seat	Hardened stainless steel
7	* O-ring	NBR; EPDM; PTFE; etc.
8	* Valve spring	AISI 302 / 1.4300
9	Piston	AISI 316 / 1.4401
9A	* O-ring	NBR; EPDM; Viton; etc.
11A	* O-ring	NBR; EPDM; PTFE; etc.
12	Gasket	Aluminium
13	Spring plate	AISI 304 / 1.4301
15	* Adjustment spring	Spring steel
16	Top spring plate	Brass
17	Adjustment screw	AISI 304 / 1.4301
18	Locknut	Stainless steel A2-70
19	Handwheel	Plastic
20	Spring id. plate	Aluminium

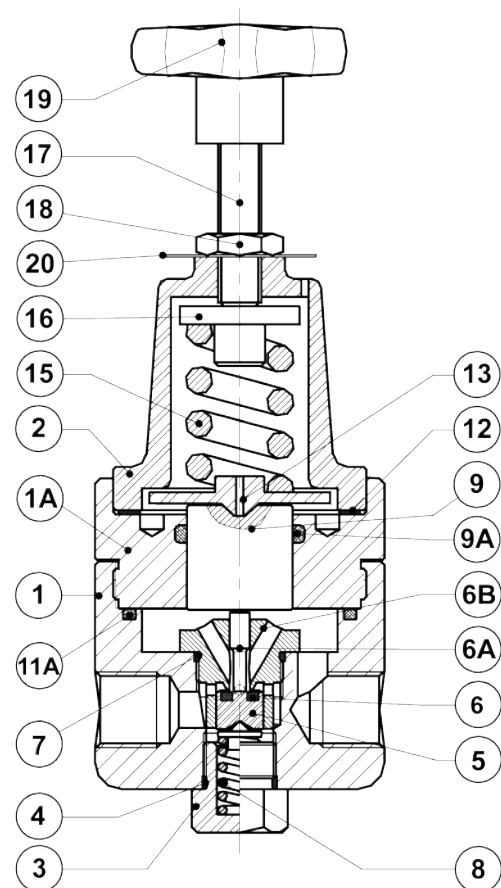

* Available spare parts.

Remarks: All valves have a serial number. In case of non-standard valves this number must be supplied if spare parts are ordered.

ORDERING CODES PRV41												
Valve model	R41	.	5	W	N	E	4	R	.	A	08	
PRV41SS – Piston sensing pressure reducing valve	R41											
Regulating range												
N°5 – 3 to 30 bar			5									
N°6 – 5 to 50 bar			6									
N°7 – 20 to 200 bar			7									
Application												
Water				W								
Gases				G								
Oxygen (degreased)				O								
Seal material												
NBR					N							
EPDM					E							
PTFE a)					T							
FPM / Viton					V							
Maximum inlet pressure												
80 bar						E						
220 bar						F						
Gauge port 1/4"												
Without gauge ports										(1)		
Gauge port on the left side (relative to the flow direction)										4		
Gauge port on the right side (relative to the flow direction)										3		
Gauge ports on both sides										2		
Relieving												
Non-relieving											(1)	
Relieving (only for non dangerous gases)											R	
Pipe connection												
Female threaded ISO 7 Rp												A
Female threaded NPT ASME B1.20.1												C
Socket weld (SW) ASME B16.11												H
Butt weld (BW) ASME B16.25												I
Flanged EN 1092-1 PN 40												N
Flanged EN 1092-1 PN 63												O
Flanged EN 1092-1 PN 100												P
Flanged EN 1092-1 PN 160												Q
Flanged EN 1092-1 PN 250												R
Flanged EN 1092-1 PN 320												S
Flanged ASME B16.5 Class 150												U
Flanged ASME B16.5 Class 300												V
Flanged ASME B16.5 Class 600												W
Size												
1/4"												08
3/8"												10
1/2" or DN 15												15
Special valves / Extras												
Full description or additional codes have to be added in case of non-standard combination.												E

(1) Omitted if a standard valve is requested.

a) Valve seal only, other seals in Viton.